

# KADET "566"



## BUILDING INSTRUCTION

This model is Copyright protected.  
All Copyrights to the designs of this  
version of the Kadet belongs to  
Billing Boats® Denmark Aps



[www.billingboats.com](http://www.billingboats.com)

DK

#### KADET

Bundplade nr. 1 samt hjælpespanterne 2 og 3 skal afpasses efter skroget, inden delene limes på. Dvs. at alle kanter skal gøres skrå (slibes i smig), således at de slutter tæt til skroget. Pres aldrig delene ned i skroget med magt.

Det er bedst at lime træ og plastik sammen med kontaklim. Placer dækket og hold det fast med tøjklammer, indtil limen er tør.

Når bundpladen og stolperne 3a og 3b er monteret, fastgøres gummiliste nr. 8 med kontaklim eller sekundlim.

Placer karmplisterne 7 og fenderliste nr. 9 og fastgør dem fra indersiden gennem skroget med små søm. Efter at listen er blevet bejdset, males den med klar lak, da bejdse ikke er vandfast.

Snit tegningen viser, hvordan de forskellige komponenter som stævnør, rør osv. er indbygget. Hvis modellen skal kunne sejle, skal der fyldes smørefedt i stævnørret, således at der ikke trænger vand ind. Det samme gælder roret.

GB

#### KADET

Bottom plate 1 and auxiliary ribs 2 and 3 must be sanded to suit the hull before the parts are glued into position, i.e. all edges must be bevelled (sanded to fit) so that they sit tight against the hull. Never try to force parts into place in the hull.

It is best to glue wood and plastic together with contact adhesive. Position the deck and secure it with clothes pegs until the glue is dry.

When bottom plate and beams 3a and 3b are fitted secure rubber strip 8 with contact adhesive or quick-drying adhesive.

Place coaming strips 7 and fender strip no. 9. Fasten them from inside using small pins. After strips are stained, apply clear lacquer - the stain is not water-resistant.

The cross-sectional drawing shows how the various components are to be built in - stern tube, rudder etc. If the model is to be sailed, the stern tube must be filled with grease to prevent the ingress of water. The same applies to the rudder.

D

#### KADET

Bevor man die Bodenplatte 1 und die Hilfsspannen 2 und 3 einleimt, sollten diese Teile in den Rumpf eingepasst werden. Das heisst, alle Kanten müssen so angeschrägt (in Schmiege geschliffen) werden, dass diese optimal am Rumpf anliegen, niemals mit Gewalt Teile in den Rumpf pressen.

Holz und Plastik lässt sich am besten mit Kontaktleim verbinden. Das Deck anbringen und bis zum Trocknen des Leims mit Wäscheklammern festklemmen.

Nachdem die Grundplatte und die Stützen 3a und 3b angebracht sind, das Gumminband 8 mit Kontaktkleber oder Blitzkleber befestigen. Sülleisten 7 sowie Fenderleiste 9 anbringen. Mit kleinen Nägeln von innen durch den Rumpf sichern. Nachdem die Leisten gebeizt sind, mit Klarlack streichen, da Beize nicht wasserfest ist.

Die Schnittzeichnung zeigt, wie die einzelnen Komponenten - wie Stevenrohr, Ruder etc. - eingebaut werden.

Soll das Modell schwimmen, nicht vergessen, das Stevenrohr mit Fett zu füllen, um ein Eindringen von Wasser zu verhindern. Das gilt auch für das Ruder.

## KADET

La base inférieure 1 et les couples auxiliaires 2 et 3 doivent être poncés pour s'ajuster précisément avec la coque avant de les coller en place, les bords doivent être biseautés pour reposer contre la coque. Ne pas forcer pour mettre les pièces en place dans la coque. Il est préférable de coller les pièces en bois sur le plastique avec de la colle contact. Positionner le pont et le maintenir en place avec des pinces à linge jusqu'au séchage complet.

Après avoir fixé la base inférieure et les pièces 3a et 3b, coller le joint caoutchouc 8 avec de la colle contact ou cyanoacrylate. Placer le longeron 7 et la baguette de protection 9. Les fixer de l'intérieur avec des petites épingles. Après avoir teinté les longerons, il faut les protéger avec du vernis résistant à l'eau.

La vue en coupe montre comment les composants, étambot, tube, gouvernail etc... sont installés. Si le modèle est destiné à naviguer, le tube d'étambot doit être rempli de graisse pour empêcher la pénétration de l'eau. Protéger le gouvernail de la même façon.

## KADET

Bestudeer eerst de bouwbeschrijving, tekeningen en de afbeelding op het deksel van de doos grondig en bouw het schip als het ware eerst in gedachten. Dit voorkomt later verrassingen. Controleer ook de inhoud van de doos aan de hand van de inhoudsopgave en maak Uzelf vertrouwd met onderdelen en benamingen. De kleurnummers worden in driehoekjes op de tekening aangegeven en de beslagdelen zijn met een "F" gemerkt.

De randen van bodemplaat 1 en spanten 2, 3, 3a en 3b moeten afgeschuind worden zodat ze precies op de romp aansluiten - nooit forceren ! Lijm de spanten en de bodemplaat in de romp. Lijm hout op plastic met behulp van contactlijm.

Lijm het dek op de romp en zet het met wasknijpers vast tot de lijm droog is. Lijm de het rubberprofiel nr. 8 om het dek heen met contact- of secondenlijm. Lijm verstevigingsbalkje nr. 6 onder tegen het dek, frame-randen nr. 7 op het dek en berghouten nr. 9 op de romp. Deze laatste beitsen en daarna met blanke lak behandelen, daar de beits niet watervast is.

Op de dwarsdoorsnede kan men zien hoe en waar de diverse onderdelen aangebracht worden, zolas de schroefas, roer enz. Indien er met de boot gevaren gaat worden, moeten de schroefaskoker en de koker van het roer met vet gevuld worden om het binnendringen van water tegen te gaan.

Voor het bouwen van de opbouw en het plaatsen van de beslagdelen, volg de tekeningen.

## KADET

La placa de fondo no. 1 y las cuadernas extra No. 2 y 3 deben adaptarse al casco antes de que se peguen con cola. O sea, todos los cantos deben ser biselados de manera que cuadren perfectamente con el casco. Nunca debe montar las partes con fuerza. Madera y plástico se unen mejor con cola de contacto. Colocat la cubierta y mantenerla en su propio lugar mediante pinzas hasta secada la cola.

La placa de fondo y los pilares 3a y 3b ya están montados. Aplicar el listón de goma No. 8 con cola de contacto o cola de segundo. Colocar los listones de marco No. 7 y listones de defensa No. 9 y fijarlos desde el interior con pequeñas clavijas a través del casco. Después de que el liston haya sido tratado con mordiente hace falta aplicar una capa de laca transparente, ya que el mordiente no protege contra el agua.

En el plano con el corte transversal se puede apreciar cómo se debe montar diferentes componentes, como por ejemplo el tubo del eje de la hélice, el timón, etc. Si el modelo es para navegar, hace falta aplicar grasa en el tubo del eje de la hélice para impedir la entrada del agua. Esto también vale para el timón.

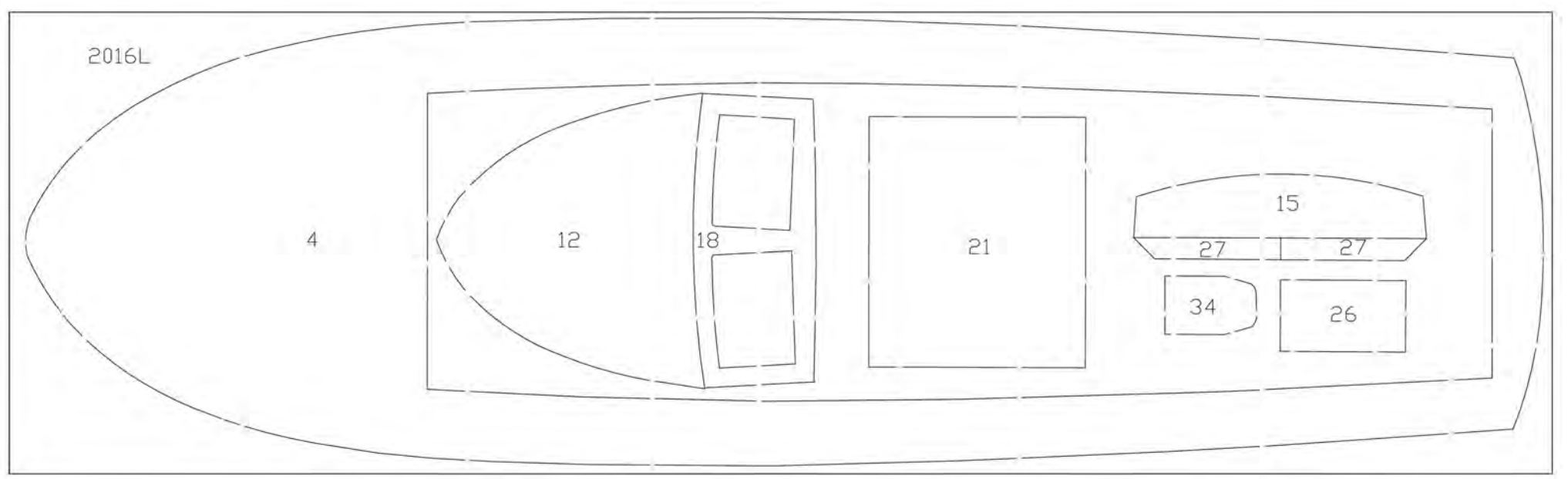
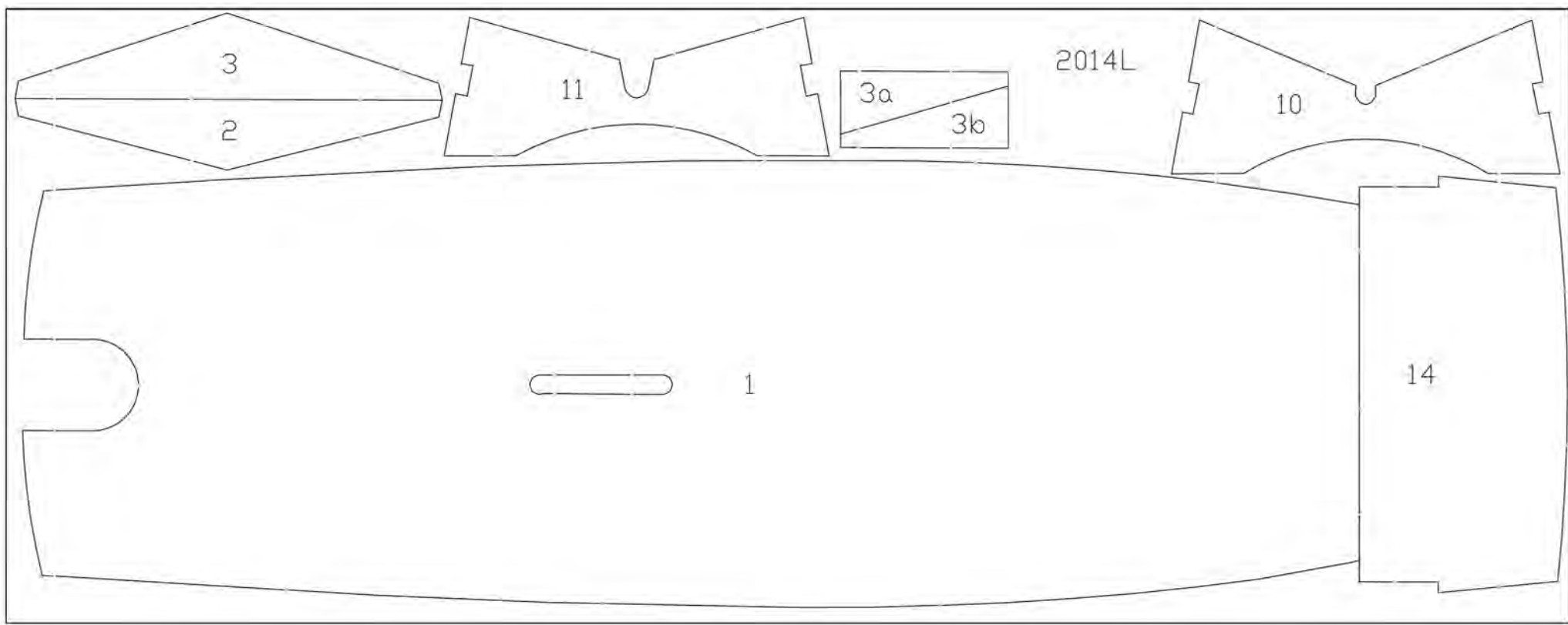

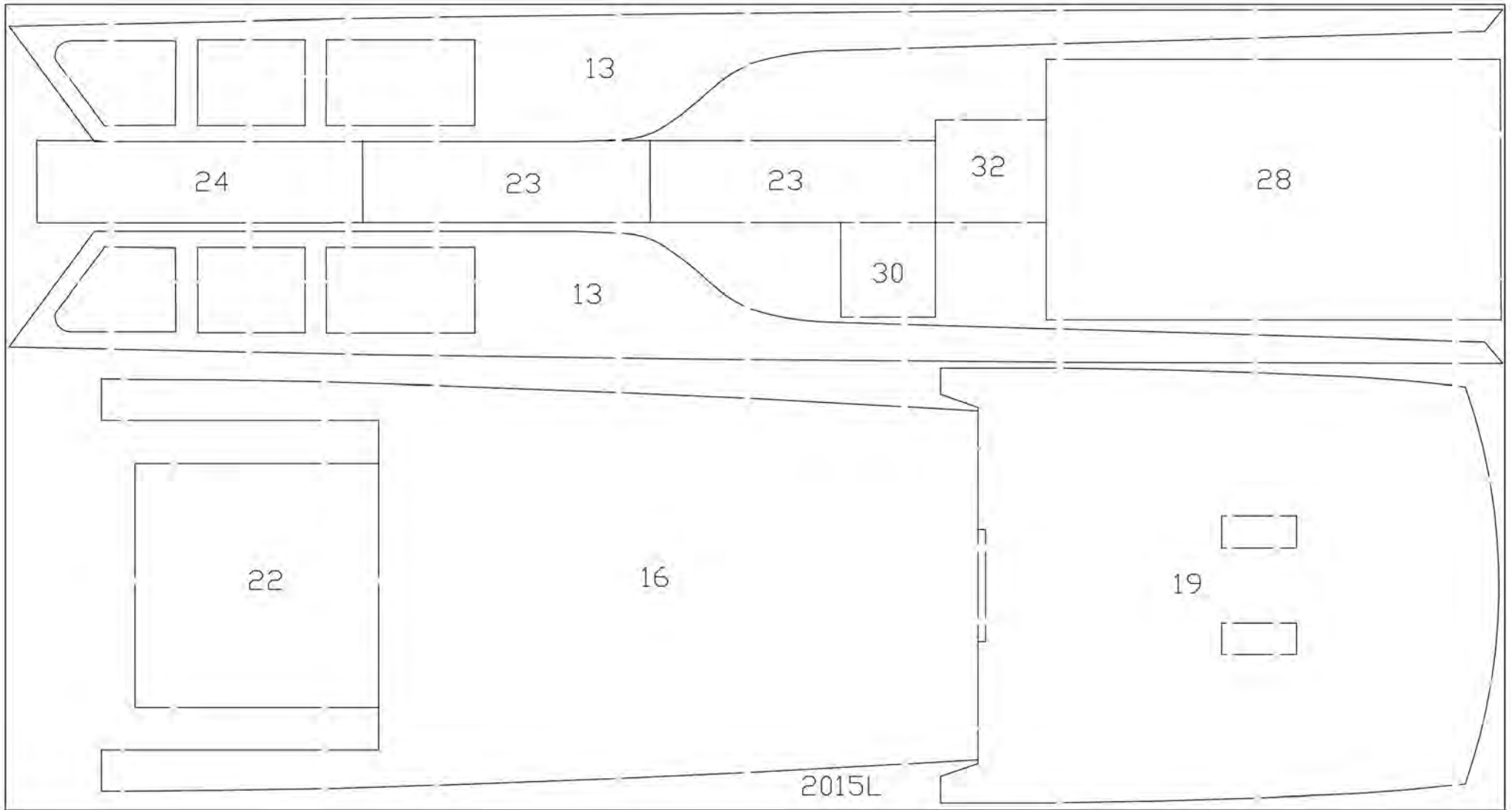

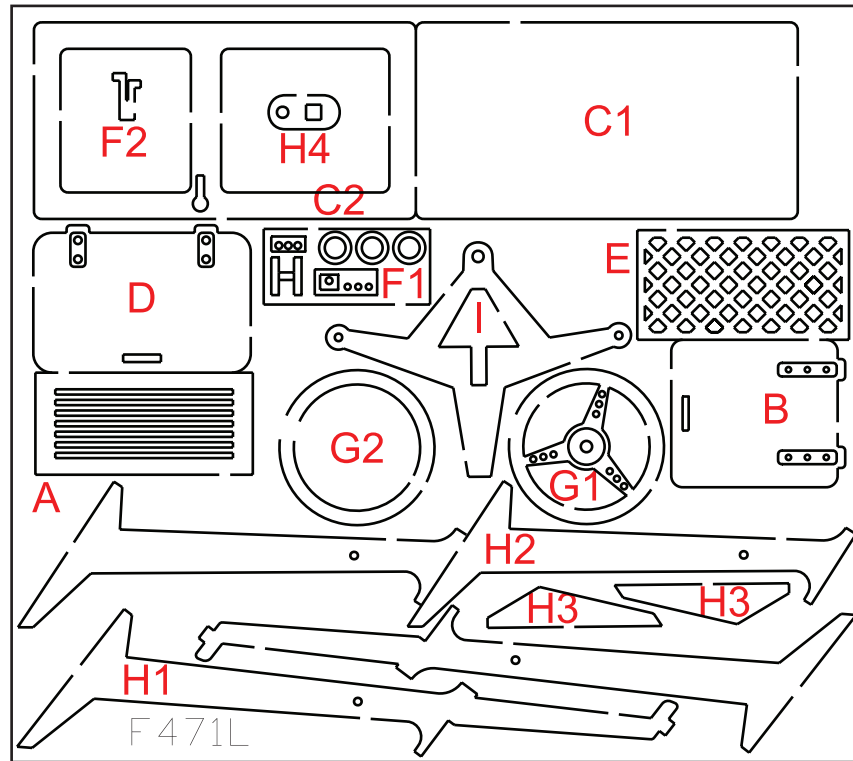



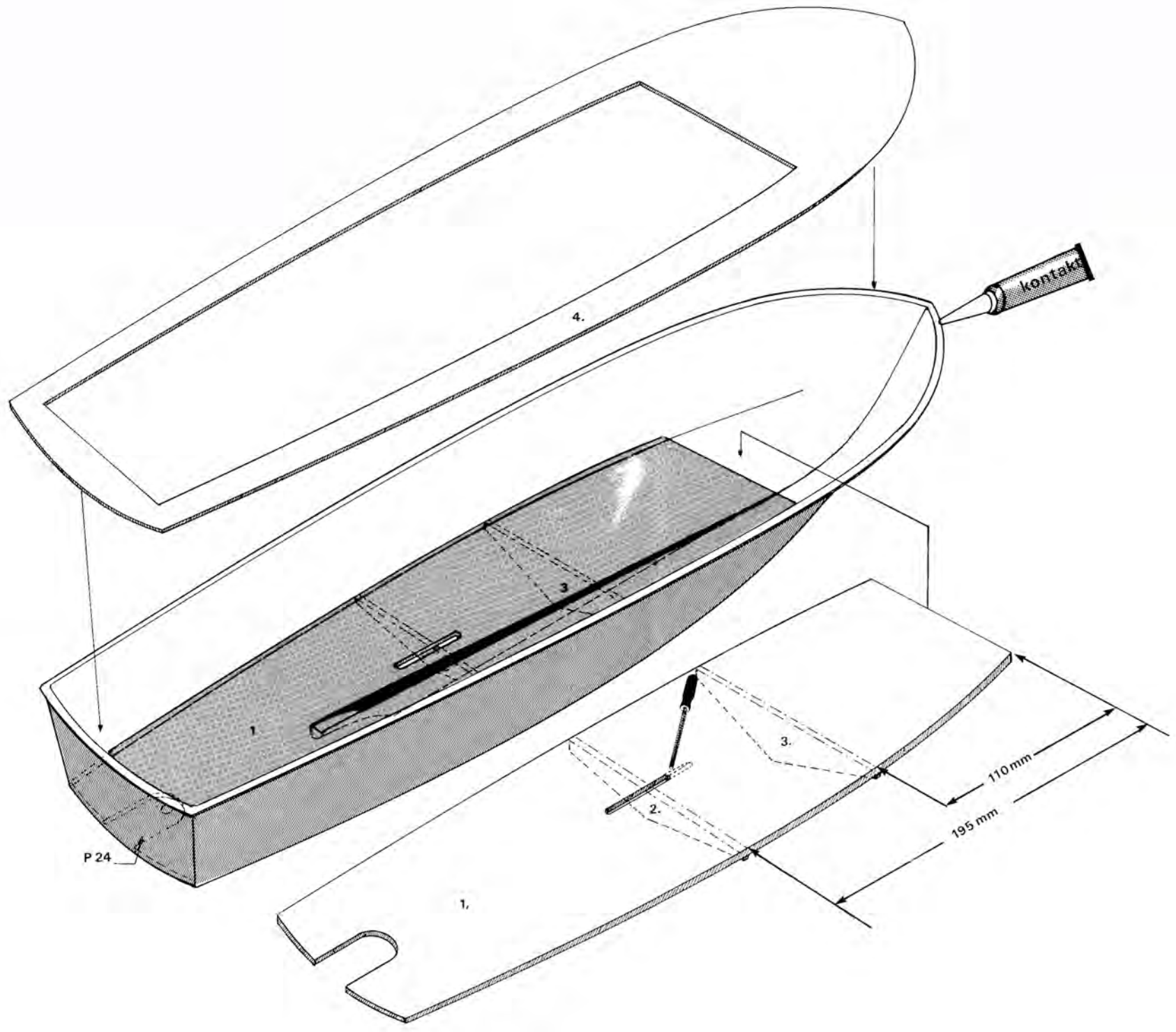

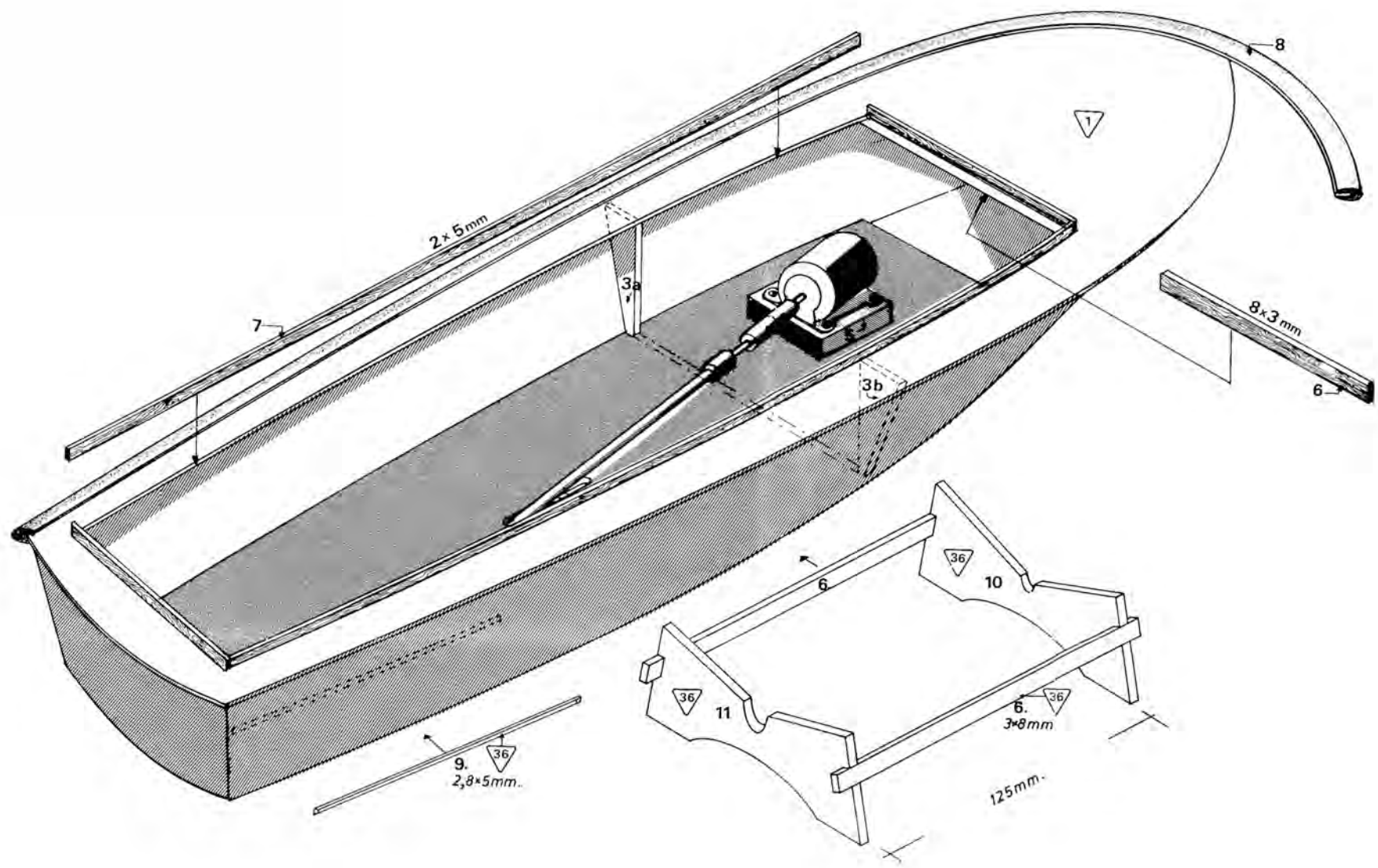



CHANGES MADE TO MAIN DRAWING

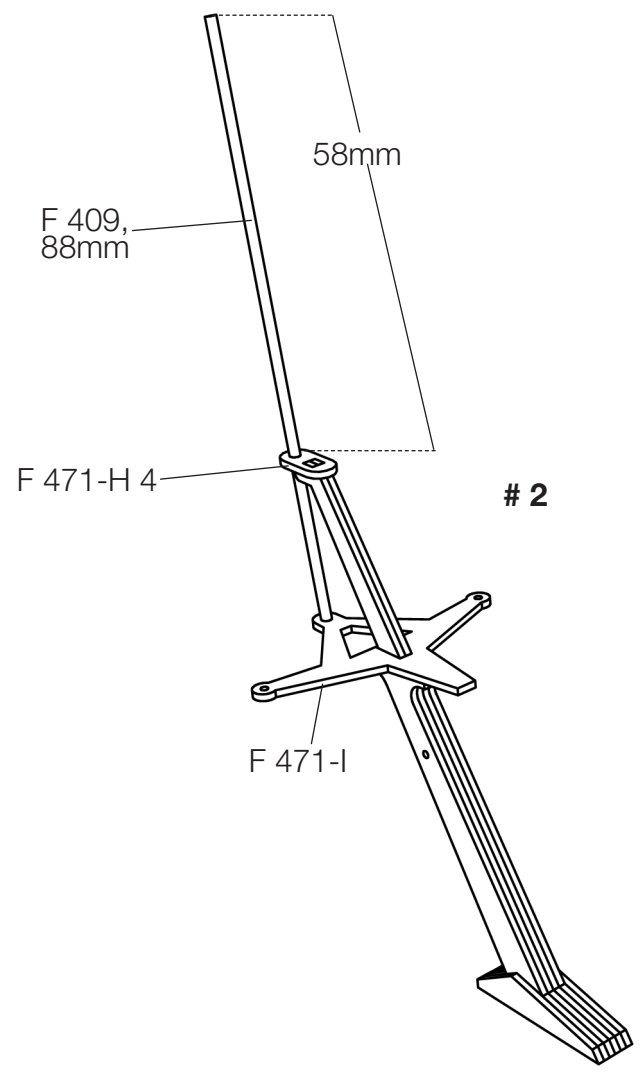
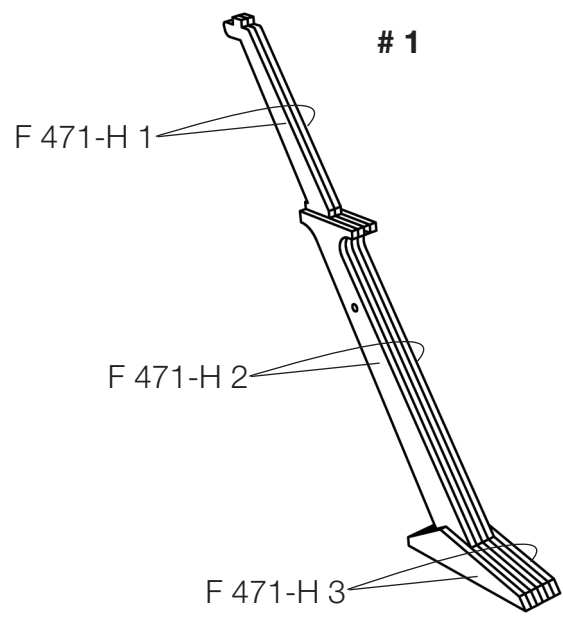
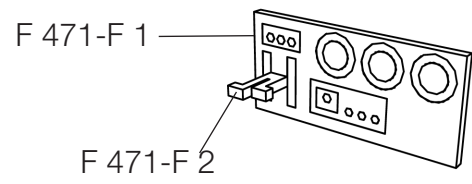
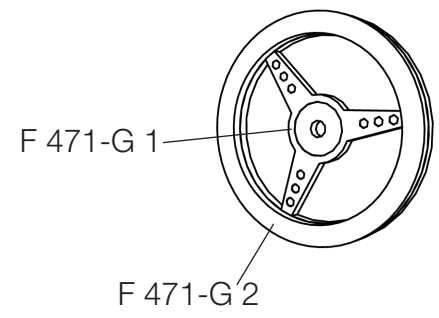
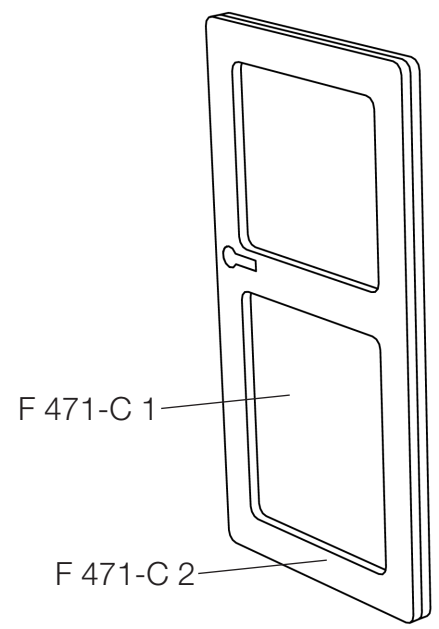

F 331

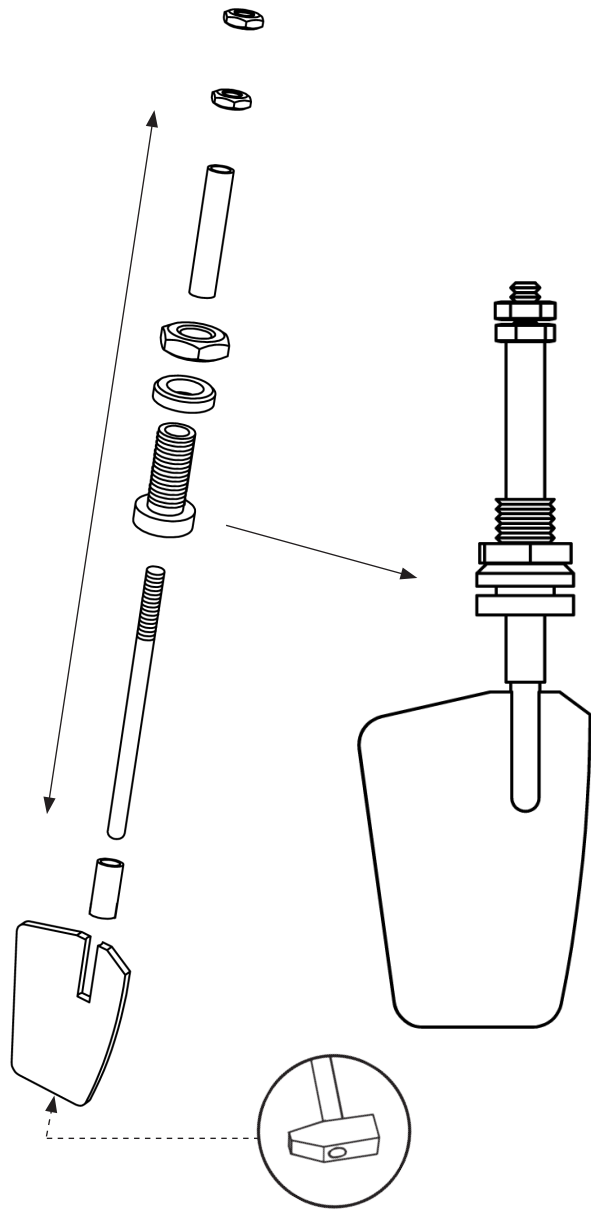

F 141

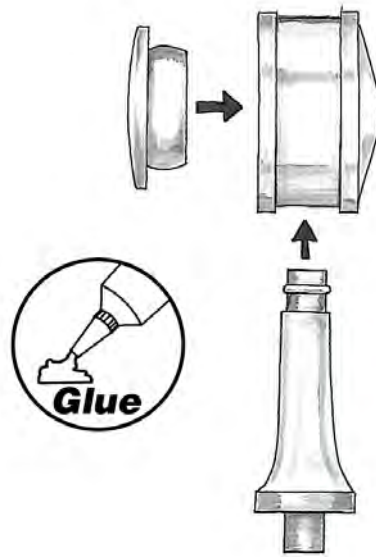

F 391

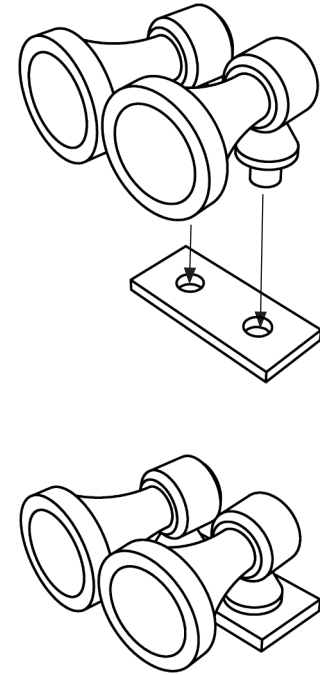





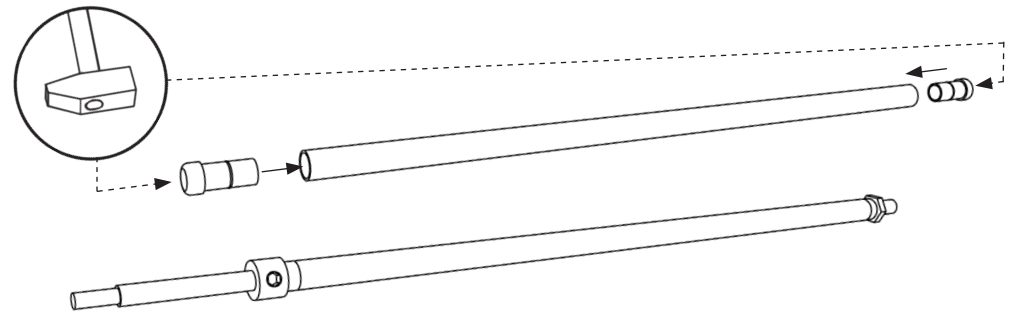

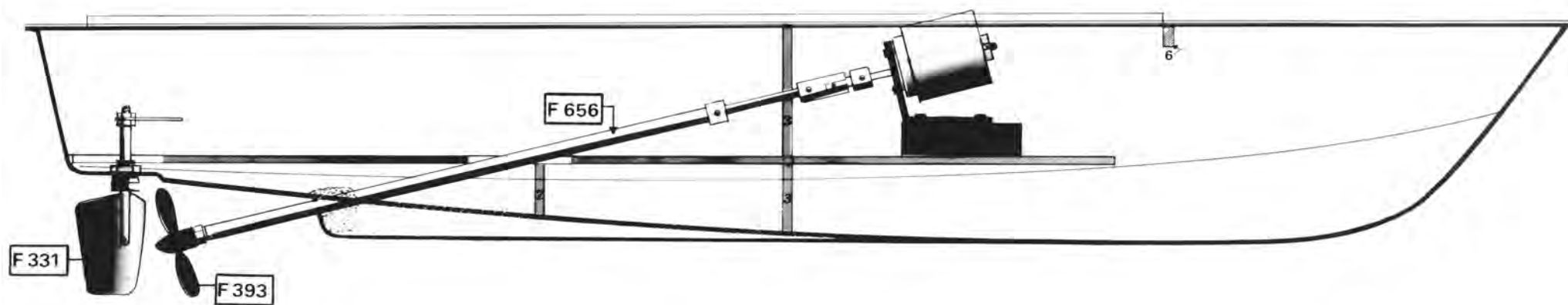
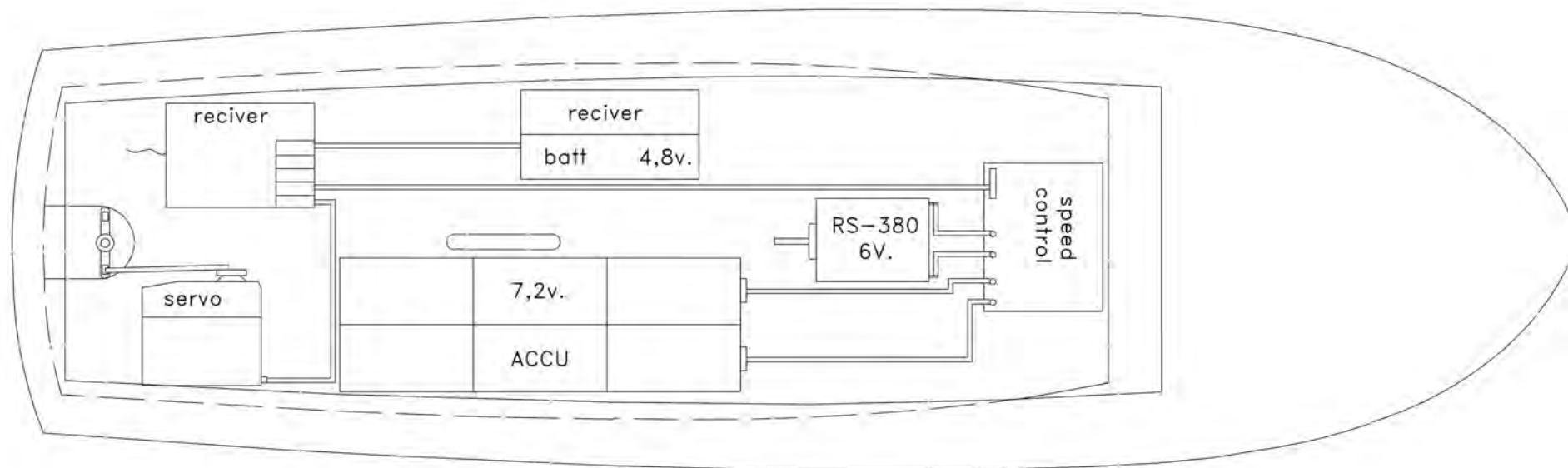
10



F 656













Symboler		=	Rigningsnummer
		=	Farvenummer
		=	Bejdse



Symbols		=	Rigging No.
		=	Colour No.
		=	Stain



Zeichen		=	Take! Nr.
		=	Farben Nr.
		=	Beize

Symboles		=	Greement no.
		=	Couleur no.
		=	Mordant

Symbo!en		=	Tuigage Nr.
		=	Kleur Nr.
		=	Beits

Símbolo		=	Oparejo Nr.
		=	Color Nr.
		=	Mordiente

Segno		=	Attrezzatura N°
		=	Colore N°
		=	Inchiostro tint.

Simbolos		=	Cordame n°
		=	Cõr n°
		=	Tintura

Til denne model er bejdse og farver med følgende numre nødvendige:

For this model is stain and colours with the following numbers should be used:

Für dieses Modell sind Beize und Farben mit den folgenden Nummern notwendig:

Pour ce modèle, le mordant et les couleurs avec les numéros suivants doivent être employées:

Voor dit model zijn kleuren met de volgende nummers nodig:

Para est modelo se necesitan mordiente et colores con los siguientes números:

Per questo Omodello occorrono inchiostro tinteggiatore "mogano" e colori con questi numeri:

Pinte o modelo com tintura cõr Mogno e as cõres sugeridas da Billing Boats:

Billing	1	=	Humbrol	22
Billing	3	=	Humbrol	2
Billing	4	=	Humbrol	18
Billing	6	=	Humbrol	177
Billing	9	=	Humbrol	19
Billing	16	=	Humbrol	11
Billing	18	=	Humbrol	48

Table of contents for 'Kadet' Art No. 566.

Pcs.	No.	Dimension	Material	DK	GB	D	F	NL	E
		P24		Skrog	Hull	Rumpf	Coque	Romp	Casco
		P104		Stol	Chair	Stuhl	Chaise	Stoel	Silla
1	1	3mm x-veneer	2014 L	Bundplade	Sole-plate	Bodenplatte	Trôle borde des fonds	Boden-plaat	Placa de fondo
1	2	3mm x-veneer	2014 L	Spant	Frame	Spant	Couple	Spant	Cuaderna
1	3	3mm x-veneer	2014 L	Spant	Frame	Spant	Couple	Spant	Cuaderna
2	3a-b	3mm x-veneer	2014 L	Støtte	Support	Stütze	Support	Steunen	Columna
1	4	2mm x-veneer	2016 L	Dæk	Deck	Deck	Pont	Dek	Cubierta
1	5	30 x 35 x 8 mm	Obechi	Klods	Block	Klotz	Poulie	Blok	Block
1	6	3 x 8 x 500 mm	Pine	Liste	Strip	Leiste	Baguette	Strip	Listón
2	7	1,8 x 5 x 550 mm	Obechi	Liste	Strip	Leiste	Baguette	Strip	Listón
1	8	1250 mm		Gummiprofil	Rubberprofile	Gummiprofil	Profil de gomme	Rubberprofiel	Perfil de goma
2	9	2,8 x 5 x 390 mm	Obechi	Liste	Strip	Leiste	Baguette	Strip	Listón
1	10	3mm x-veneer	2014 L	Bedding	Slip	Helling	Cale	Standaard	Grada
1	11	3mm x-veneer	2014 L	Bedding	Slip	Helling	Cale	Standaard	Grada
1	12	2mm x-veneer	2016 L	Plade/stævn	Plate/stem	Platte/vorsteven	Lame/étrave	Plaat/voorsteven	Placa/proa
2	13	2mm x-veneer	2015 L	Side/kahyt	Side/cabin	Seite/kajüte	Cote cabine	Zijde/kajuit	Lado/camarote
1	14	3mm x-veneer	2014 L	Skot	Bulkhead	Schott	Cloison	Schot	Mamparo
1	15	2mm x-veneer	2016 L	Bord/kahyt	Table/cabin	Tisch/kajüte	Table/cabine	Tafel/kajuit	Mesa/camarote
1	16	2mm x-veneer	2015 L	Agterdæk	Sterndeck	Achterdeck	Dunette arrière	Achterdek	Linterna de popa
1	17	6 x 6 x 100 mm	profil	Liste	Strip	Leiste	Baguette	Strip	Listón
1	18	2mm x-veneer	2016 L	Front/kahyt	Front/cabin	Kajütenstücke	Pièce-cabine	Kajuitstukken	Frente/camarote
1	19	2mm x-veneer	2015 L	Tag/kahyt	Roof/cabin	Dach/kajüte	Toit/cabine	Dak/kajuit	Techo/camarote
1	20	132x222mm		Acetat/vinduer	Acetate/windows	Azetat/fenster	Rhoidid/fenêtres	Acetaat/venster	Acetato/ventana
1	21	2mm x-veneer	2016 L	Gulv/cockpit	Floor/cockpit	Boden/cockpit	Plancher/cockpit	Vloer/cockpit	Piso/bañero
1	22	2mm x-veneer	2015 L	Gulv/cockpit	Floor/cockpit	Boden/cockpit	Plancher/cockpit	Vloer/cockpit	Piso/bañero
2	23	2mm x-veneer	2015 L	Side/cockpit	Side/cockpit	Seite/cockpit	Cote/cockpit	Zijde/cockpit	Lado/bañero
1	24	2mm x-veneer	2015 L	Ende/cockpit	End/cockpit	Ende/cockpit	Bout/cockpit	Eind/cockpit	Tapa/bañero
1	25	20 x 26 x 15 mm	Obechi	Klods	Block	Klotz	Poulie	Blok	Taco
1	26	2mm x-veneer	2016 L	Front/styrepult	Instrumentboard	Instrumentconsol	Planche d'instrum.	Instrumentenplank	Tabla de instrumentos
1	27	2mm x-veneer	2016 L	Side/styrepult	Instrumentboard	Instrumentconsol	Planche d'instrum.	Zijde/instr. plank	Tabla de instrumentos
1	28	2mm x-veneer	2015 L	Plade/agterdæk	Plate/stern	Platte/heck	Lame/arrière	Plaat/achter	Platt/linterna de popa
1	29	22 x 22 x 4 mm	Obechi	Klods	Block	Klotz	Poulie	Blok	Taco
1	30	2 mm plywood	2015 L	Dæksel/luge	Cover/hatch	Deckel/luke	Couvercle/écouille	Deksel/luike	Tapa/escotilla
1	31	28 x 15 x 15 mm	Pine	Klods	Block	Klotz	Poulie	Blok	Taco
1	32	26 x 30 x 1 mm	X-veneer	Dæksel/udluftn.	Cover/airing	Deckel/lüftung	Couvercle/ventilation	Deksel/luchten	Tapa/aeración
1	33	0,7 x 2 x 550 mm	Mahogany	Liste	Strip	Leiste	Baguette	Strip	Listón
1	34	2mm x-veneer	2016 L	Ryg/sæde	Back/chair	Stuhllehne	Dossier/chaise	Stoelrug	Respaldo/asiento
1	F 471L-A	1mm x-veneer	F 471L	Ristværk	Grating	Gråting	Grillage	Roosterwerk	Emparillado



1	F 471L-B	1mm x-veneer	F 471L	Luge	Hatch	Luken	Ecoutilles	Luiken	Escoutilla
2	F 471L-C 1+2	1mm x-veneer	F 471L	Dør	Door	Tür	Portes	Deur	Puerta
1	F 471L-D	1mm x-veneer	F 471L	Luge	Hatch	Luken	Ecoutilles	Luiken	Escoutilla
1	F 471L-E	1mm x-veneer	F 471L	Ristværk	Grating	Gråting	Grillage	Roosterwerk	Emparillado
2	F 471L-F 1+2	1mm x-veneer	F 471L	Kontrolbord	Control Panel	Kontroltisch	Table de contrôle	Kontroltafel	Mesa de controló
2	F 471L-G 1+2	1mm x-veneer	F 471L	Rat	Steering wheel	Steuerrad	Roue	Stuurwiel	Volante
4	F 471L-H 1-4	1mm x-veneer	F 471L	Mast	Mast	Mast	Mât	Mast	Palo
1	F 471L-I	1mm x-veneer	F 471L	Mast	Mast	Mast	Mât	Mast	Palo
1		A4		Byggevejledning	Building Instruction	Bauanleitung	Instr. de montage	Bouwbeschrijving	Instrucciones de construccion
		(8108-1) + (8108-2-3)		Tegninger	Drawings	Zeichnungen	Plans	Tekening	Dijubo
1		TR 104		Transfer	Transfer	Abziehbild	Transfer	Transfer	Transfer

Table of contents for "fittings" Kadet no. 566.

Pcs.	No.	Dimension	Material	DK	GB	D	F	NL	E
2	F24	ø20mm		Redningsbælte	Lifebelt	Rettungsring	Ceinture de sauvetage	Reddingsboei	Cinturones salvavidas
1set	F34	23mm		Lanternekasser	Boards for sidel.	Laternenkasten	Planchettes/feux de pos.	Lichtbakken	Cajas para linternas
1	F35	61mm		Flagstang	Flagstaff	Flaggenstock	Gaule de pavillon	Vlaggestok	Asta de bandera
1	F37	30mm		Anker	Anchor	Anker	Ancre	Anker	Ancla
4	F39	ø1 x 250 mm		Messingtråd	Brasswire	Messingdraht	Fils de laiton	Messingdraad	Hilo de latón
5	F41	12mm		Klyds	Fairlead	Klüssen	Ecubiers	Verhaalklampen	Bocina
1	F70	500 mm		Tråd/mast	Thread/mast	Draht/mast	Fil/mâts	Draad/mast	Hilo/palo
1	F72	200 mm		Tråd/anker	Thread/anchor	Draht/Anker	Fil/ancre	Draad/anker	Hilo/ancla
1	F100	ø4mm		Lanterne	Latern	Laterne	Feu de navigation	Boordlicht	Linternas
2	F121	ø6mm		Lanterne	Latern	Laterne	Feu de navigation	Boordlicht	Linternas
1	F141	10mm		Spotlight	Searchlight	Scheinwerfer	Projecteurs	Schijnwerper	Reflector
1	F177	23x20mm		Ramme	Frame	Rahmen	Cadre	Lijst	Marco
10	F298	7mm		Gelænderstøtte	Rail-stanchions	Relingstützen	Chandeliers	Railingpalen	Soporte de pasamanos
1	F331			Ror	Rudder	Ruder	Gouvernail	Roer	Timón
10	F371	32mm		Gelænderstøtte	Rail-stanchions	Relingstützen	Chandeliers	Railingpalen	Soporte de pasamanos
1	F389	18mm		Sokkel/stol	Underlay/chair	Unterlage/Stuhl	Socle/chaise	Console/stoel	Base/Silla
1	F391	12mm		Sirene	Siren	Sirene	Sirène	Sirene	Sirena
1	F396	20mm		Klampe	Cleat	Klampe	Taquet	Kikker	Cornamusas
1	F398R	ø40mm	Skruer	Propeller	Schiffsschraube	Hélice	Schroet	Hélice	
1	F409-1	ø1,5 x 90 mm	Brass	Brasswire	Messingdraht	Fil de laiton	Messingdraad	Hilo de latón	
1	F471			Plastløb	Plastic casting	Plastguss	Fonte de plastique	Kunststofgieten	Piezas de plástico fundido
1	F493	17mm		Gelænderstøtte	Rail-stanchions	Relingstützen	Chandeliers	Railingpalen	Soporte de pasamanos
1	F619	24mm		Rorarm	Piece for rudder	Teil für Ruder	Piece p. gouvernail	Deel f. Roer	Brazo de Timón
1	F656	210mm		Skrueraksel	Propeller shaft	Stevenrohr	Arbre porte hélice	Schroefas	Je de hélice
4	F664	11mm		Øjebolt	Eyebolt	Augenbolzen	Pitons	Oogbauten	Pernos de cánamo
1	F691			Alumåtte	Aluminium mat	Alumatte	Natte d'aluminium	Alumat	Felpudo de aluminio



F41



F100



F121



F298



F664



F396



F391

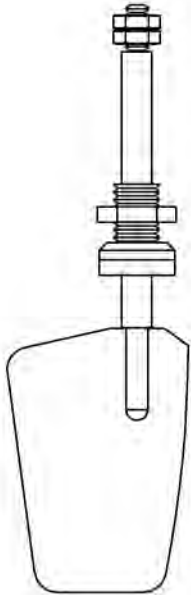

F331



F35

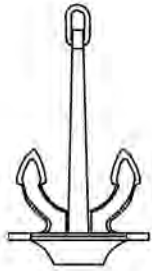

F37



F389



F493



F141



F619



F371

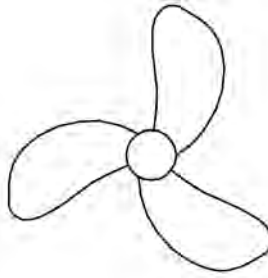

F398/R

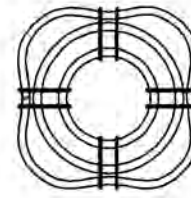

F24

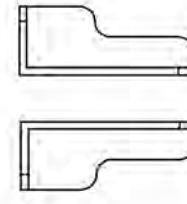

F34

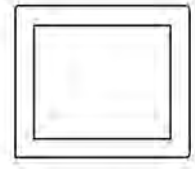

F177

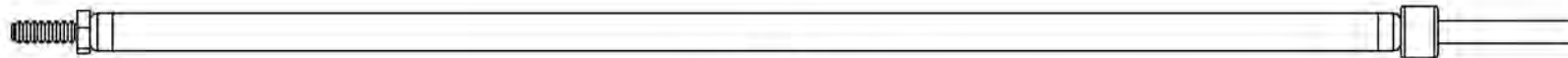

F656



F409

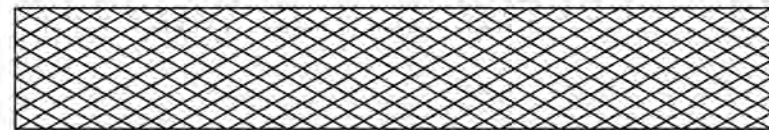

F691



F39

