

COLIN ARCHER “606”



This model is Copyright protected.
All Copyrights to the designs of this
version of the Colin Archer belongs
to Billing Boats Denmark Aps

07.06.18

www.billingboats.com

DK

Norsk redningskutter nr. 1 "Colin Archer".

RS1 blev for "Norsk selskab til skibsbrudnes redning" bygget i 1893 på Colin Archer værftet i Rekkevig ved Larvik, Norge. RS1 blev døbt "Colin Archer" efter sin konstruktør og bygger.

"Colin Archer" blev gennem sin spidsgatter konstruktion senere verdensberømt.

Der blev bygget ca. 30 fartøjer af denne type. De fleste på Colin Archers værft på Tollerodden i Larvik.

RS1 Colin Archer har haft en bevæget fortid: 40 år som sejrende redningskutter. I 1933 blev Colin Archer solgt til private, som lagde en lille hjælpemotor i, 1938 over Atlanten, oktober 1954 svært beskadiget i en storm ved North Carolina, i december 1960 fundet som vrage ved Potomac River. "Colin Archer" kom tilbage til Norge december 1961, som dækslast på fragtskibet "M/S Tasco" efter 23 år i USA. Derefter forskellige ejer, og gode og dårlige tider. Endelig den 21. april 1972 blev det ældste norske redningskutter RS1 overgivet til det Norske søfartsmuseum i Oslo.

I 1973 blev ansvaret for Colin Archer overladt til sejlkutterklubben Colin Archer som har restaureret skibet totalt og sejler den som et flydende kulturminde efter aftale med Norsk Søfartsmuseum.

Idag er RS1 "Colin Archer" en meget velkommen gæst på mange veteranskibstræf i hele Nordeuropa.

GB

Norwegian salvage cutter no. 1 "Colin Archer"

RS1 was built in 1893 for the "Norwegian Society for Shipwreck Salvage" at the Colin Archer shipyard in Rekkevig near Larvik, Norway. RS1 was later named "Colin Archer" after its designer and builder. The sharp-sterned design of the vessel has given it world-wide renown. Roughly 30 boats of this type were built, most of them at the Colin Archer shipyard at Tollerodden in Larvik.

RS1 Colin Archer has had an eventful past. After 40 years as a salvage vessel, the ship was sold in 1933 to private owners, who added a small auxiliary motor. It crossed the Atlantic in 1938, suffered severe storm damage in North Carolina in October 1954, and was found as a wreck on the Potomac River in 1960. After 23 years in the USA, the Colin Archer was returned to Norway in December of 1961 as deck cargo on the freighter "MS Tasco". Then followed a series of owners - and both good and hard times. Finally, on 21 April 1972, the oldest salvage vessel in Norway was handed over to the Norwegian Maritime Museum in Oslo. In 1973, responsibility for the vessel was given to the Colin Archer Cutter Club, which has since completely restored the ship and sails it, in agreement with the Norwegian Maritime Museum, as a functioning reminder of the past.

Today the Colin Archer is a welcome guest at vintage ship gatherings in Northern Europe.

D

Norwegischer Rettungskutter Nr. 1 "Colin Archer"

RS1 wurde für die „Norsk selskab til skibsbrudnes redning“ (Norwegische Gesellschaft zur Rettung Schiffbrüchiger) 1893 auf der Colin Archer Werft in Rekkevig bei Larvik, Norwegen gebaut. RS 1 wurde nach ihrem Konstrukteur und Erbauer „Colin Archer“ benannt. „Colin Archer“ wurde durch ihre Spitzgattkonstruktion später weltberühmt. 30 Fahrzeuge dieses Typs wurden gebaut, die meisten auf Colin Archers Werft auf der Tollerodde in Larvik.

RS1 Colin Archer hat eine bewegte Vergangenheit: 40 Jahre als segelnder Rettungskutter, 1933 an Privatleute verkauft, die einen kleinen Hilfsmotor einbauten, 1938 ging die Reise über den Atlantik, im Oktober 1954 in einem Sturm bei North Carolina schwer beschädigt, im Dezember 1960 als Wrack am Potomac River entdeckt. Colin Archer kam nach 23 Jahren in den USA im Dezember 1961 nach Norwegen zurück - als Deckslast des Frachters „M/S Tasco“. Es folgten verschiedene Eigner, gute und schlechte Zeiten. Am 21. April 1972 wurde der älteste norwegische Rettungskutter, RS1 schließlich dem Norwegischen Seefahrtsmuseum in Oslo übergeben.

1973 wurde die Verantwortung für die Colin Archer dem Segelkutterklub Colin Archer übertragen, der das Schiff vollständig restaurierte und es als schwimmendes Kulturdenkmal nach Absprache mit Norsk Sjøfartsmuseum (dem Norwegischen Seefahrtsmuseum) segelt. Heute ist RS1 „Colin Archer“ ein beliebter Teilnehmer an vielen Treffen von Schiffsveteranen in ganz Nordeuropa.

F

Bateau de sauvetage norvégien numéro 1 „Colin Archer“

RS 1 a été construit en 1893 au chantier naval de R à L, Norvège, pour „La société norvégienne pour le sauvetage des naufragés“ RS1 a été baptisée „CA“ selon son constructeur.

Plus tard il a été connu dans le monde entier à cause de sa construction à arrière pointu.

On a fait 30 bateaux de ce type. La plupart au chantier naval de CA à T, L.

RS 1 a eu un passé mouvementé: 40 ans comme bateau de sauvetage actif. En 1933 CA a été vendu à des gens privés, qui ont ajouté un petit moteur auxiliaire, en 1938 traversée de l'Atlantique, en octobre 1954 gravement endommagé pendant une tempête à NC., en décembre 1960 trouvé comme épave à PR.

CA retourne en Norvège au mois de décembre 1961, après 23 ans aux Etats Unis comme cargaison sur le pont du cargo „M/S Tasco“. Après: de différents propriétaires, et du temps mauvais et du temps bon. Enfin le 21 avril 1972 le plus ancien bateau de sauvetage norvégien a été confié au musée naval norvégien d'Oslo.

En 1973 la responsabilité pour CA a été donnée au club du bateaux à voile CA qui a fait la restauration totale du bateau et qui l'utilise comme un souvenir culturel vivant selon un accord avec le musée naval norvégien.

Aujourdh'hui RS1 CA est un visiteur très bien reçu à de nombreux rendez-vous nord-européens d'anciens voiliers.

(l'esquisse), de manière qu'on puisse tirer la voile d'un côté à l'autre avec la même corde.

NL

Noors bergingsvaartuig no. RS 1 "Colin Archer"

De RS 1 werd in 1893 gebouwd door de Colin Archer Scheepswerf in Rekkevig bij Larvik, Noorwegen voor de "Norwegian Society for Shipwreck Salvage" als SV 1.

De naam SV 1 werd later veranderd in "Colin Archer", de ontwerper en bouwer van dit schip. Dit ontwerp met scherpe achtersteven, de zg. "spitsgatter", werd wereldwijd bekend. De werf in Larvik heeft meer dan 30 van deze interessante schepen gebouwd.

De RS 1 Colin Archer heeft een bewogen geschiedenis achter de rug: veertig jaar als bergingsvaartuig, verkocht aan een privé eigenaar in 1933 (die er een hulpmotor in aanbracht), oversteek van de Atlantische Oceaan in 1938, zware stormschade ter hoogte van Noord Carolina in 1954 en in 1960 als wrak gevonden op de Potomac rivier. Na 23 jaar in de Verenigde Staten werd de Colin Archer in 1961 als deklading met het motorschip Tasco terug gebracht naar Noorwegen. Hierna volgden goede en slechte tijden onder een aantal verschillende eigenaren. Uiteindelijk werd dit oudste bergingsvaartuig van Noorwegen op 21 april 1972 overgedragen aan het Noorse Scheepvaart Museum in Oslo. In 1973 werd de verantwoordelijkheid voor het schip overgedragen aan de Colin Archer Cutter Club, die het schip geheel restaureerde en er met toestemming van het Noorse Scheepvaart Museum mee vaart als een functionele herinnering aan het verleden.

Het schip is nu een graag geziene gast op zeil-manifestaties in heel Europa.

E

Barco de salvamento número 1 "Colin Archer" de Noruega

RS1 fue construido para "La sociedad noruega para el salvamento de los naufragos" en el año 1893 en el astillero de CA à Rekkevig, Larvik, Noruega. Fue bautizado "CA" según su constructor.

Debido a la construcción del barco con popa puntiguada obtuve más tarde una fama mundial.

Construyeron unos 30 barcos de este tipo. La mayoría en el astillero de CA a Tolleroden, Larvik.

RS1 CA tiene un pasado agitado: 40 años como barco de salvamento. En 1993 CA fue vendido a unos particulares que montaron un pequeño motor auxiliar, en 1938 travesía del Atlántico, en octubre 1954, seriamente dañado durante una tempestad en NC, en diciembre 1960 encontrado como buque naufragado en PR. CA vuelve a Noruega en el mes de diciembre 1961, como carga de cubierta del cargo "M/S Tasco" después de 23 años en los Estados Unidos.

Más tarde varios propietarios, y tiempos fáciles y tiempos difíciles.

Al fin, el 21 de abril 1972, el barco de salvamento noruego más antiguo fue entregado al Museo Naval de Noruega a Oslo.

En 1973 la responsabilidad para CA fue confiada al club de los barcos a vela CA, que ha renovado el barco completamente, que lo utiliza como conmemoración flotante, según un acuerdo con el Museo naval noruego. Hoy RS1 CA es un invitado muy bienvenido a las varias reuniones de barcos veterano en todo el Norte de Europa.

I

Cutter di salvataggio norvegese nr. 1 “Colin Archer”

La RS1 fu costruita nel 1893 per la “Norsk selskab til skibsbrudnes redning” (che è la Società norvegese per il salvataggio di naufraghi) nei cantieri Colin Archer di Rekkevig nei pressi di Larvik in Norvegia. Fu battezzata “Colin Archer”, dal nome del suo costruttore. Divenne in seguito famosa in tutto il mondo grazie alla sua struttura dalla poppa appuntita. Furono costruite 30 imbarcazioni di questo tipo, la maggior parte delle quali nei cantieri “Colin Archer” a Tollerodde. La RS1 Colin Archer ha un passato movimentato: per 40 anni cutter a vela di salvataggio, nel 1933 fu venduta ad un privato (che vi fece installare un piccolo motore ausiliario), nel 1938 intraprese un viaggio attraverso l’Atlantico; nell’ottobre 1954 rimase gravemente danneggiata da una tempesta e nel dicembre del 1960 ne fu rinvenuto il relitto sul fiume Potomac. La “Colin Archer” rientrò in Norvegia nel dicembre 1961, dopo 23 anni negli USA, caricata a bordo del mercantile “M/S Tasco”. Seguirono diversi proprietari, con alterna fortuna. Il 21 aprile 1972, infine, il più vecchio cutter norvegese di salvataggio fu consegnato al Museo della Navigazione di Oslo. La “Colin Archer” venne quindi nel 1973 affidata al “Club dei cutter a vela Colin Archer”, che provvide a restaurarla completamente e che da allora la utilizza come “monumento vivente”, in base ad un accordo con il Museo della navigazione norvegese. Oggi la RS1 “Colin Archer” rientra spesso tra i partecipanti più amati dei molti incontri tra le “veterane del mare” di tutto il Nordeuropa.

Cúter de salvamento noruguês nº 1 “Colin Archer”.

P

O RS1 foi construído em 1893 para a “Sociedade Norueguesa para o Salvamento dos Náufragos”, no estaleiro de Colin Archer, em Rekkevig, Larvik, Noruega. O RS1 foi batizado “Colin Archer” em homenagem ao seu idealizador e construtor.

Posteriormente, o “Colin Archer” ficou famoso por sua construção de respiradouros pontudos.

Foram construídas cerca de 30 embarcações deste tipo. A maior parte no estaleiro de Colin Archer, em Tolerodden, Larvik.

O RS1 Colin Archer teve um passado atribulado: 40 anos como cúter de salvamento. Depois, em 1933, o Colin Archer foi vendido a pessoas privadas que o equiparam com um pequeno motor; em 1938, atravessou o Mar Atlântico; em outubro de 1954, ficou gravemente danificado numa tempestade na Carolina do Norte; em dezembro de 1960 foi encontrado como destroços no Rio Potomac. O “Colin Archer” voltou para a Noruega em dezembro de 1961, como carga a bordo do navio cargueiro “M/S Tasco”, após 23 anos nos EUA. Depois, teve diferentes proprietários, e bons e maus tempos. Finalmente, em 21 de abril de 1972, o mais antigo cúter de salvamento norueguês, RS1, foi entregue para o Museu Marítimo da Noruega, em Oslo.

Em 1973, a responsabilidade pelo Colin Archer foi transferido ao clube de cúteres veleiros Colin Archer que restaurou totalmente o barco e agora navega com o mesmo como um patrimônio cultural flutuante, segundo acordo com o Museu Marítimo da Noruega.

Hoje, o RS1 “Colin Archer” é um visitante muito bem-vindo nos muitos encontros de navios veteranos realizados em todo o Norte da Europa.

FIG.1

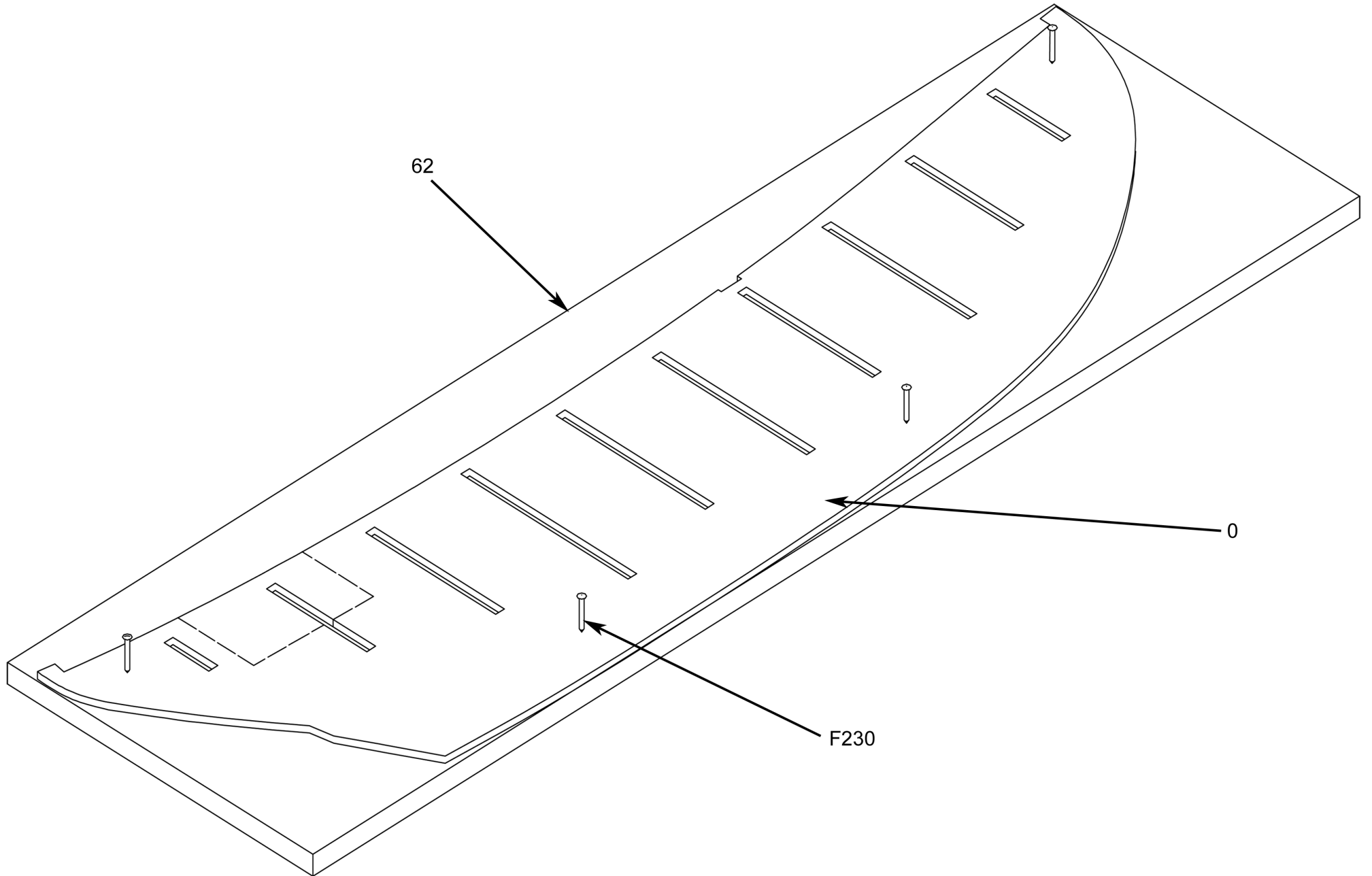

FIG.2

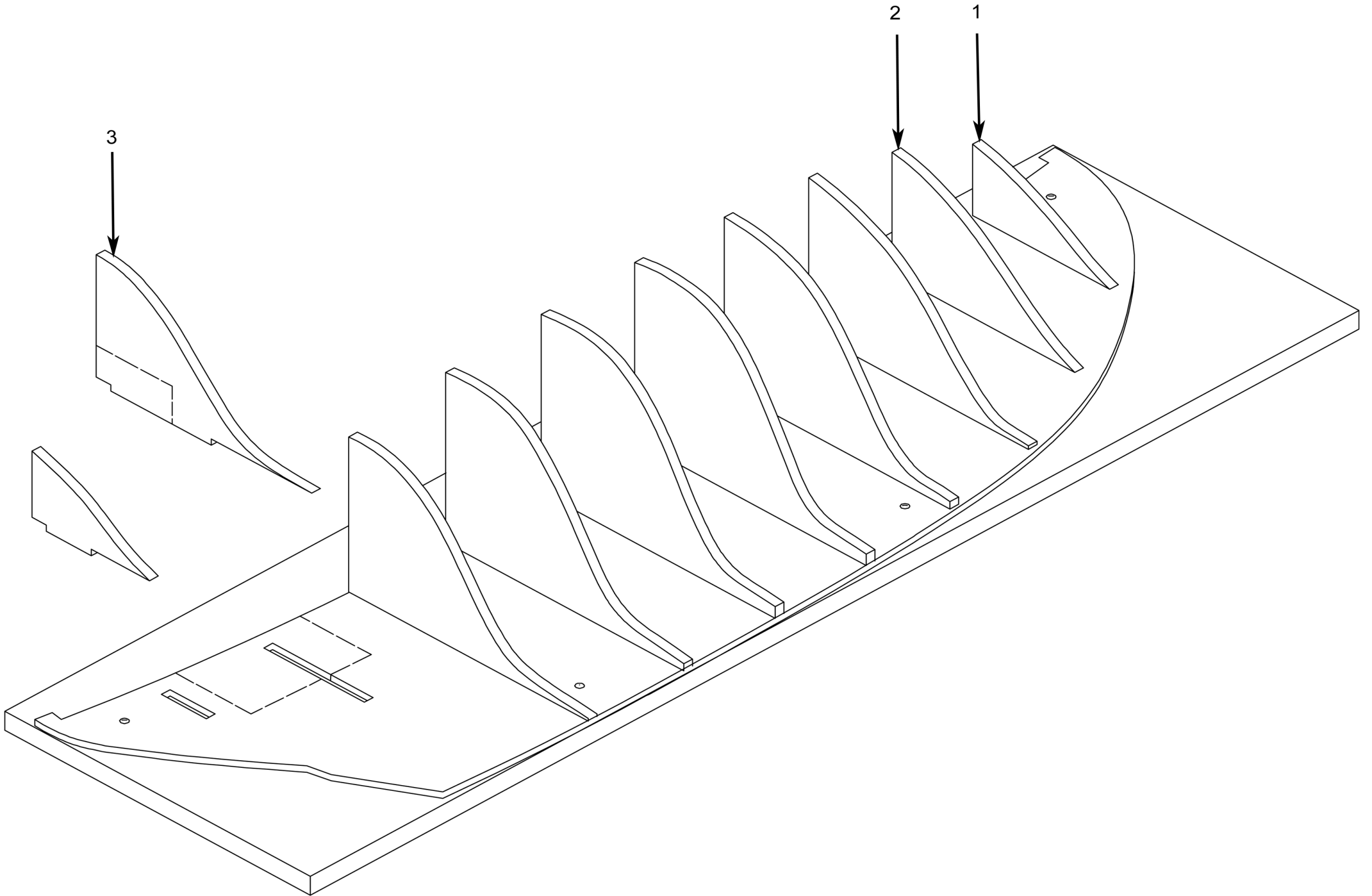

FIG.3

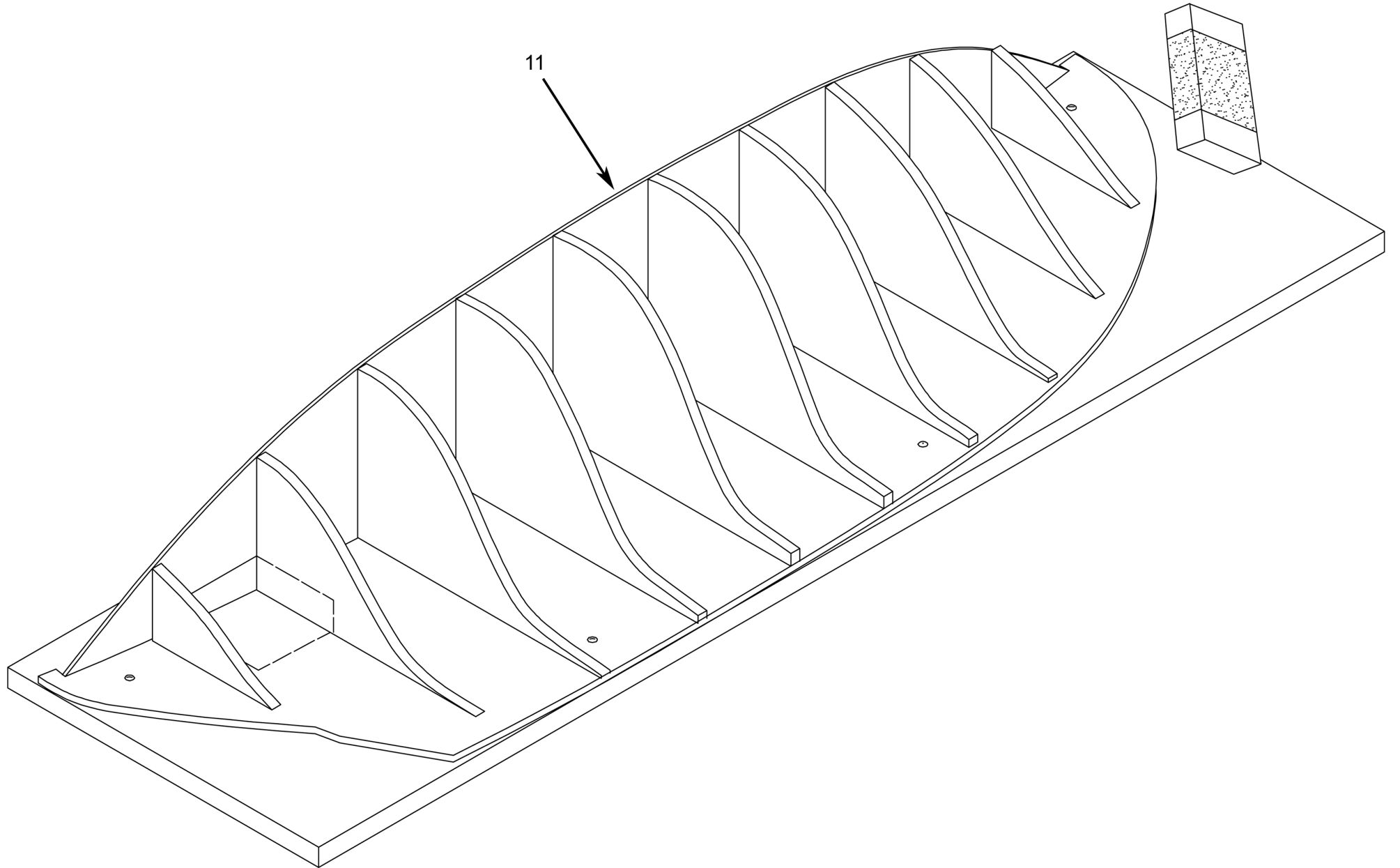

FIG.4

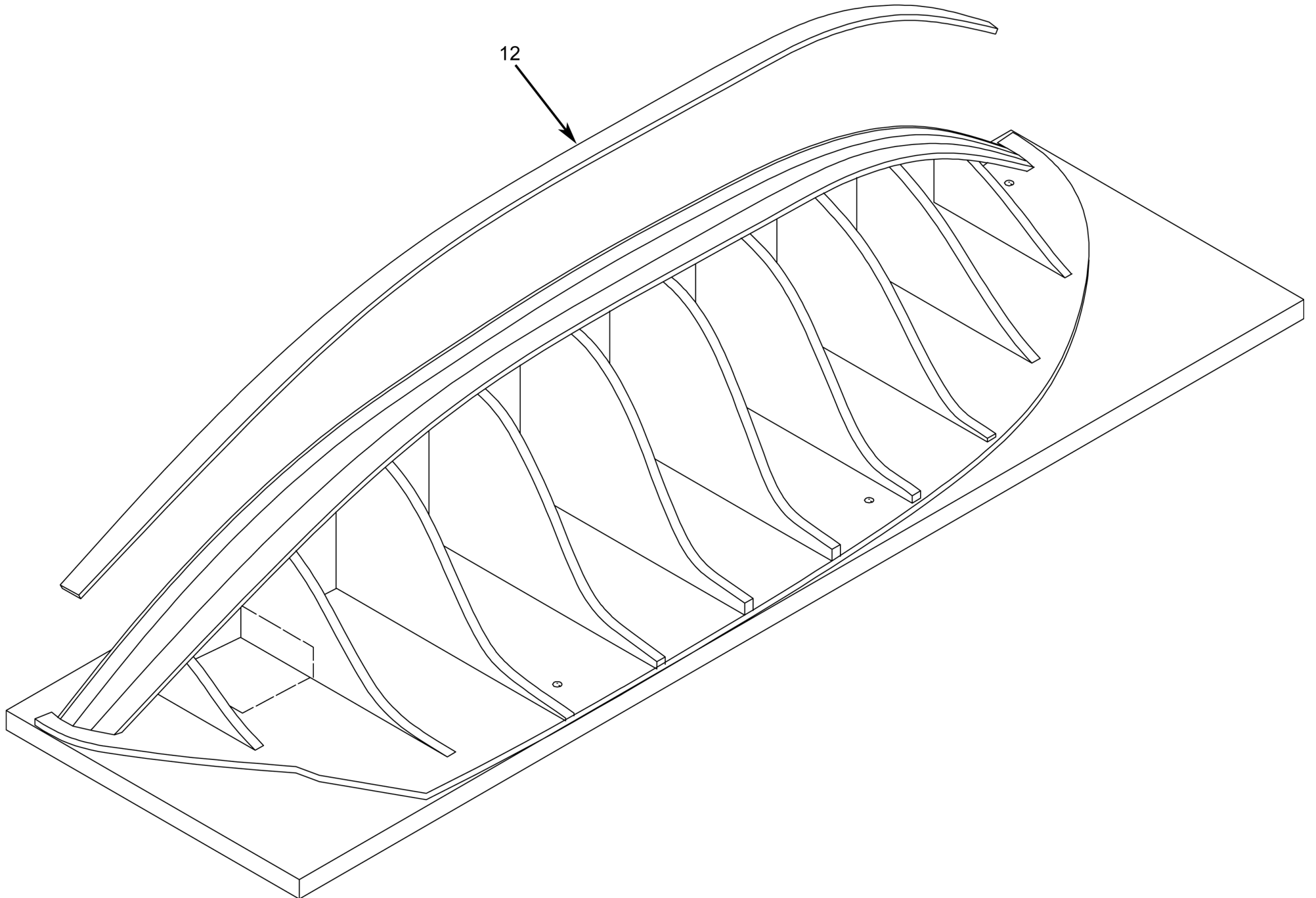

FIG.5

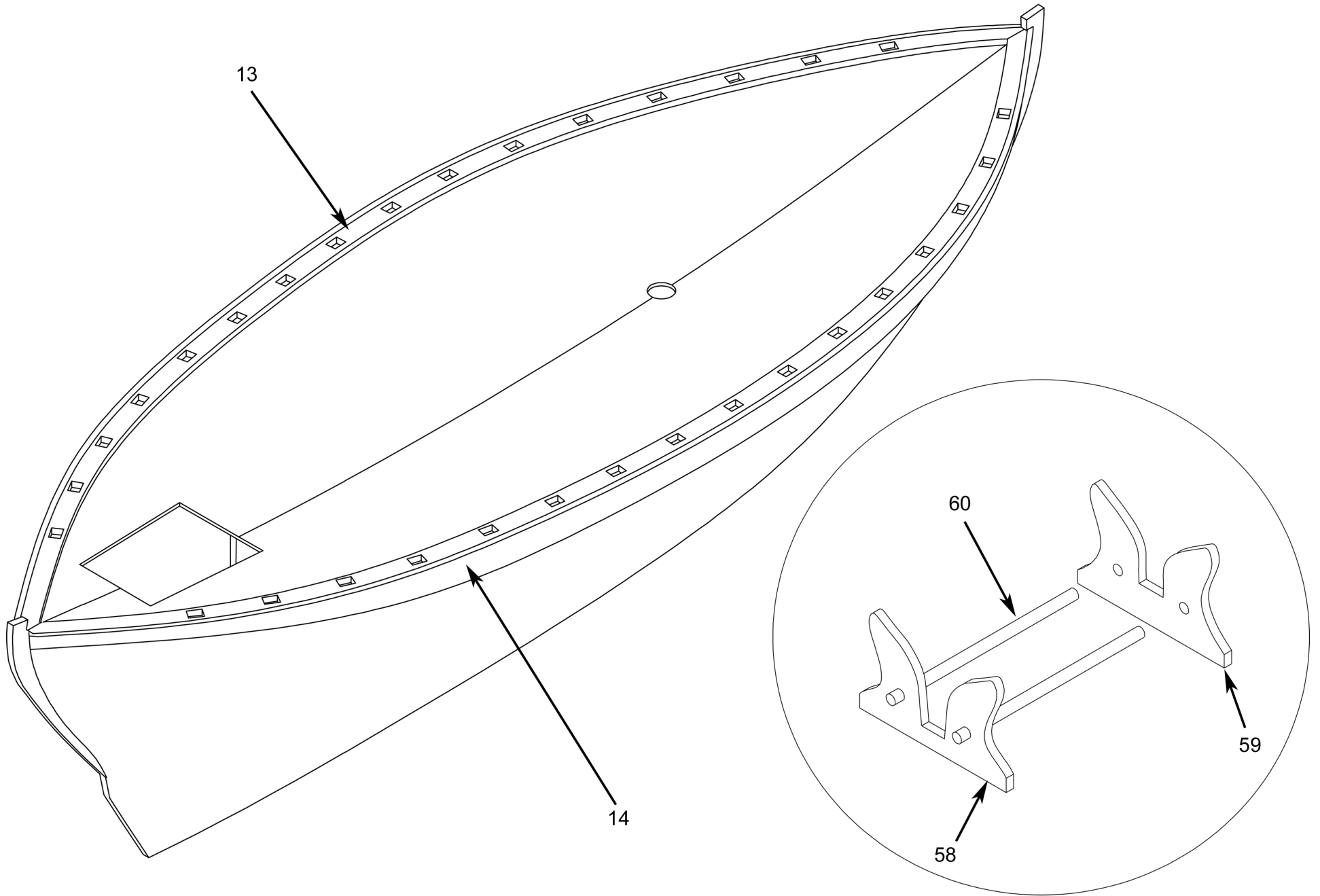

FIG.6

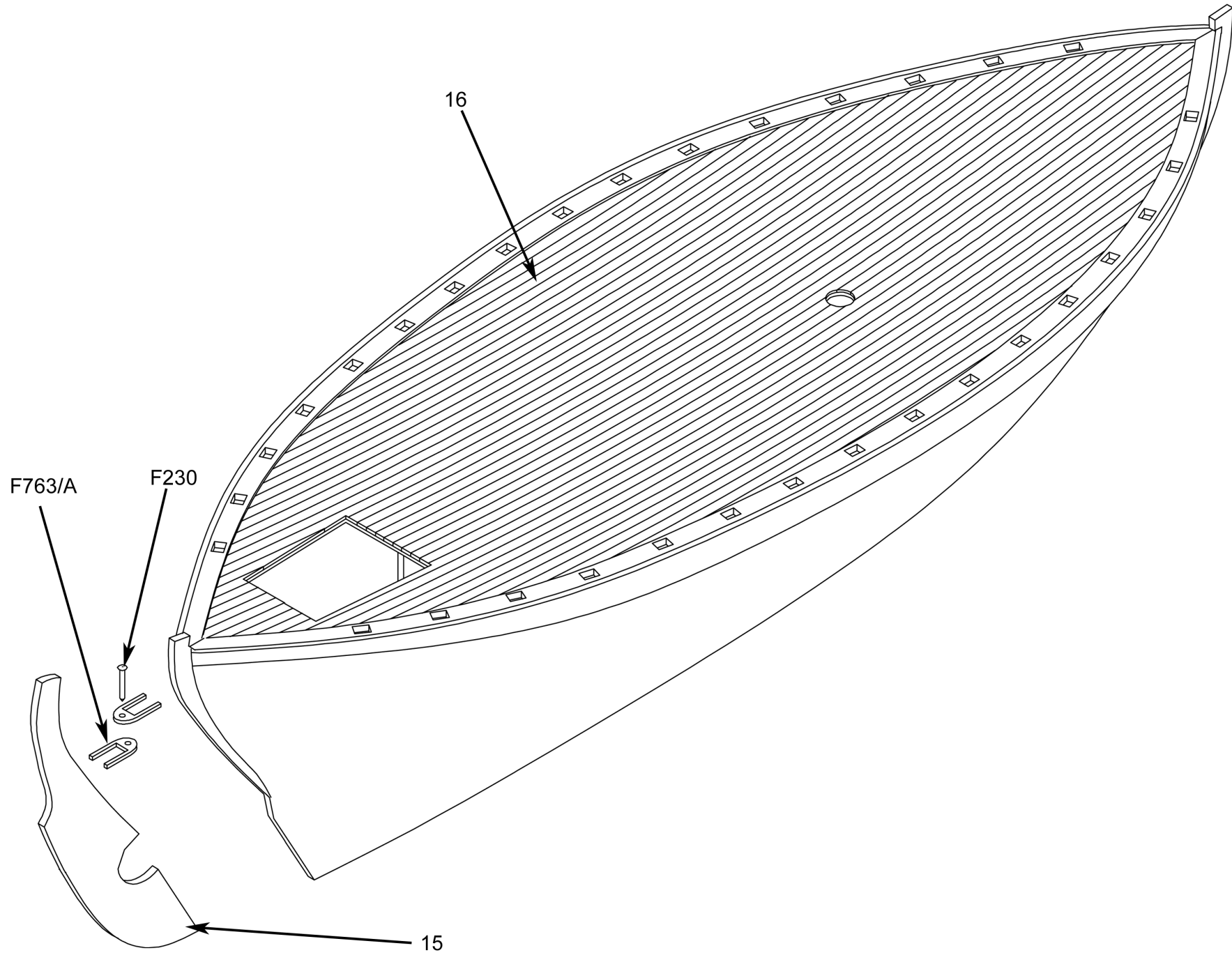
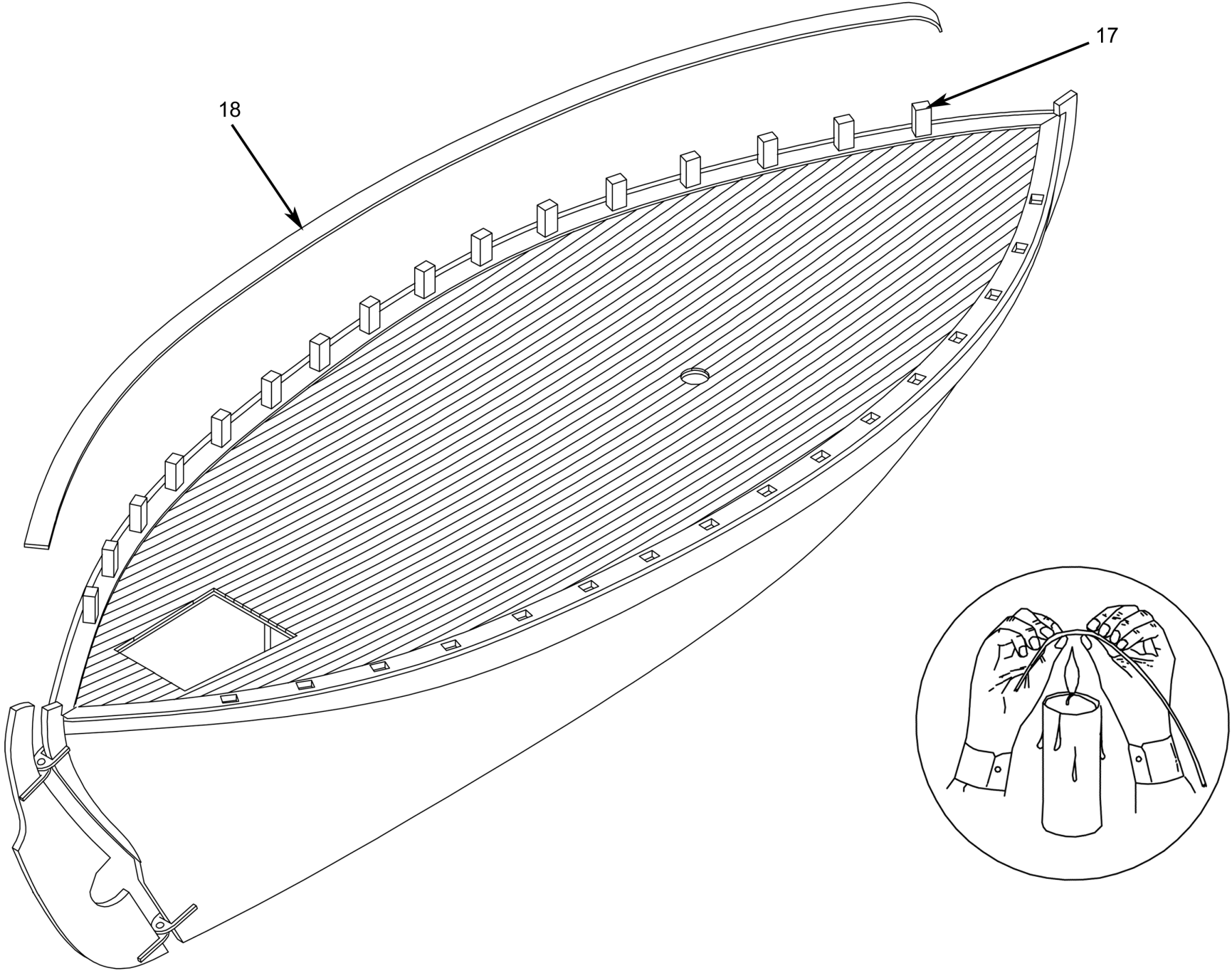

FIG.7



18

17

FIG.8

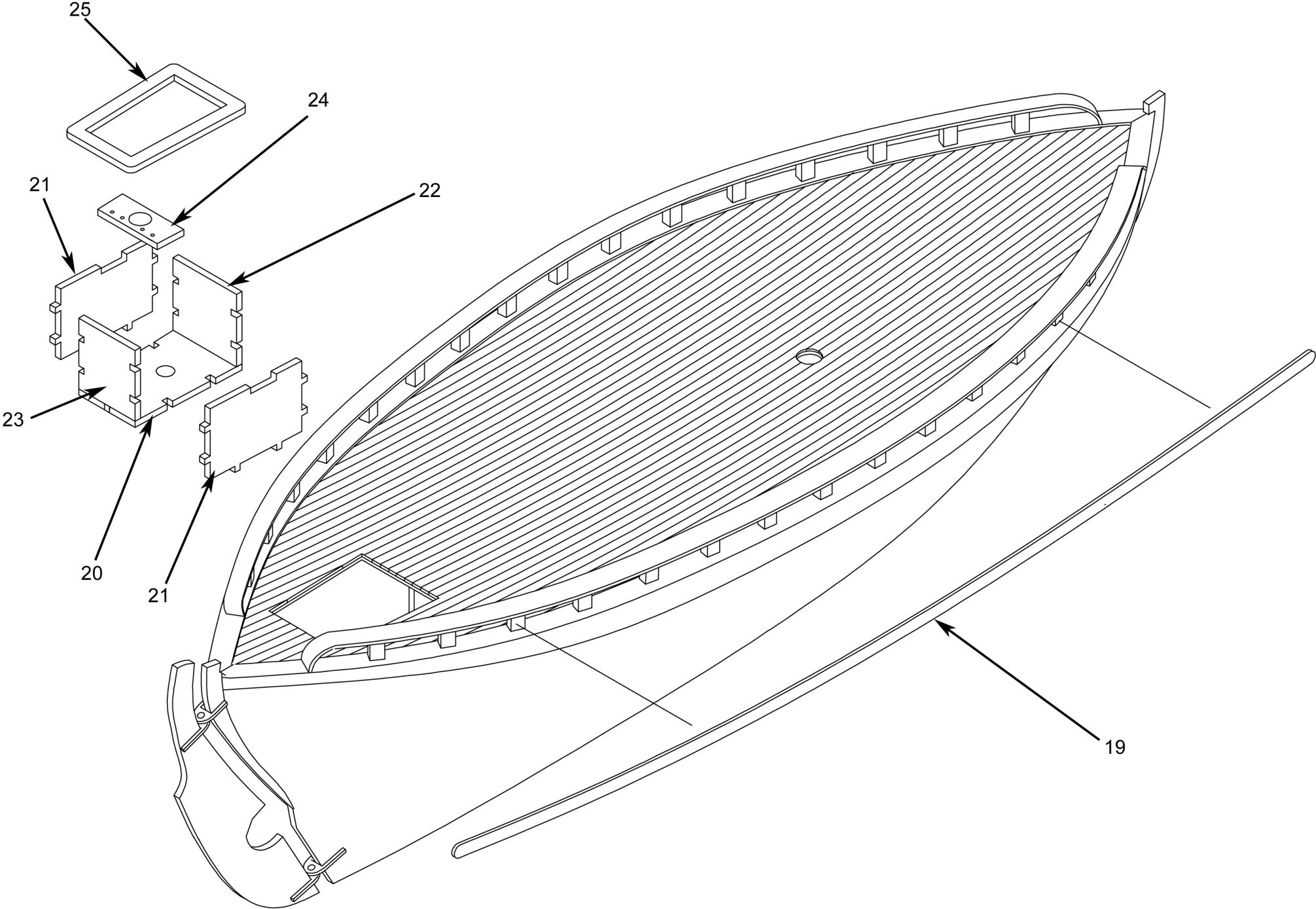

FIG.9

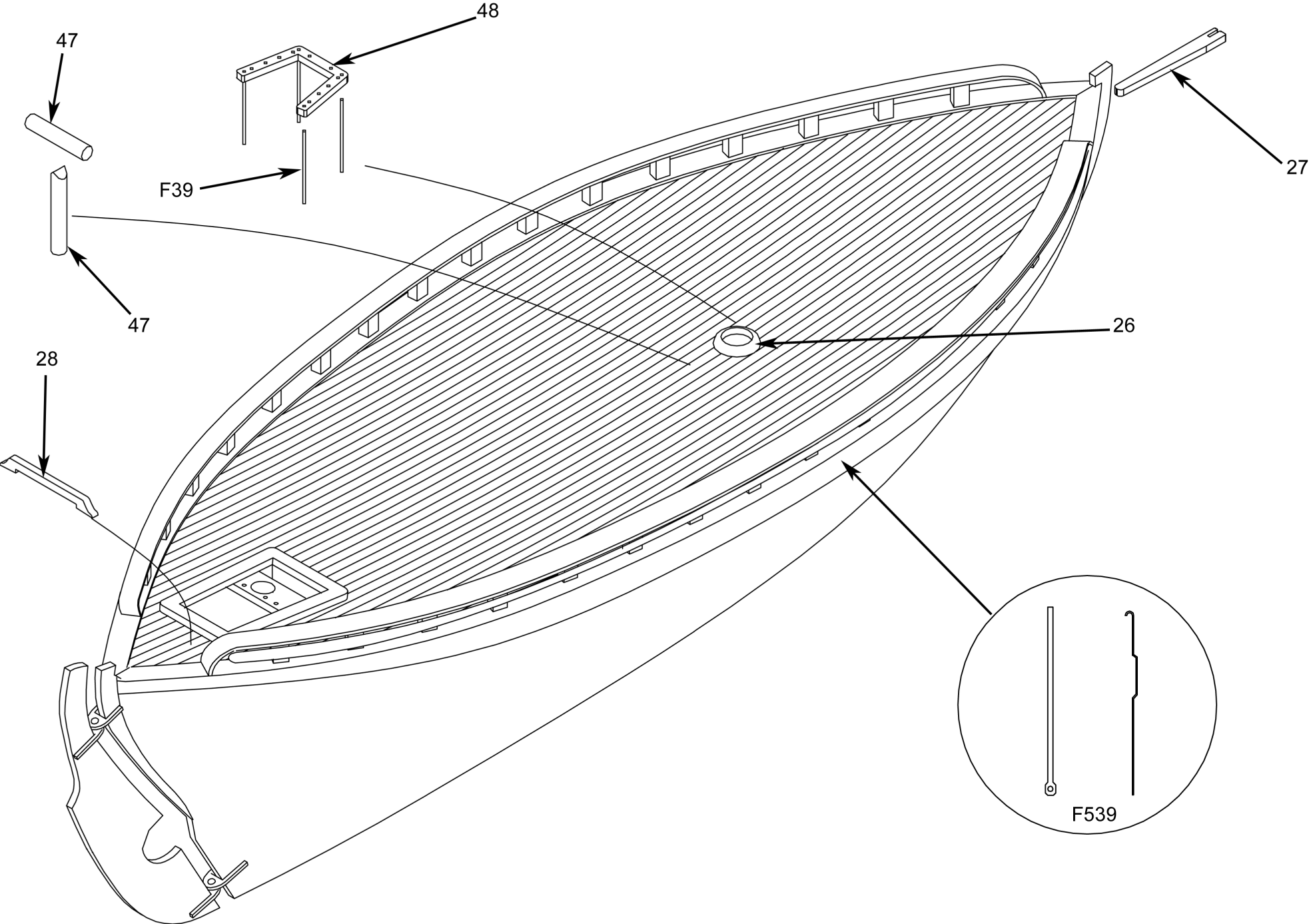
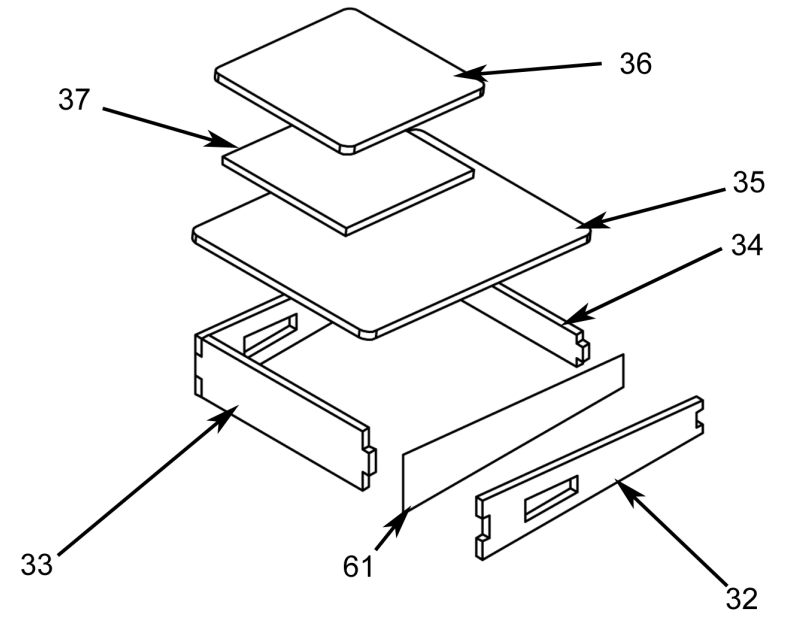
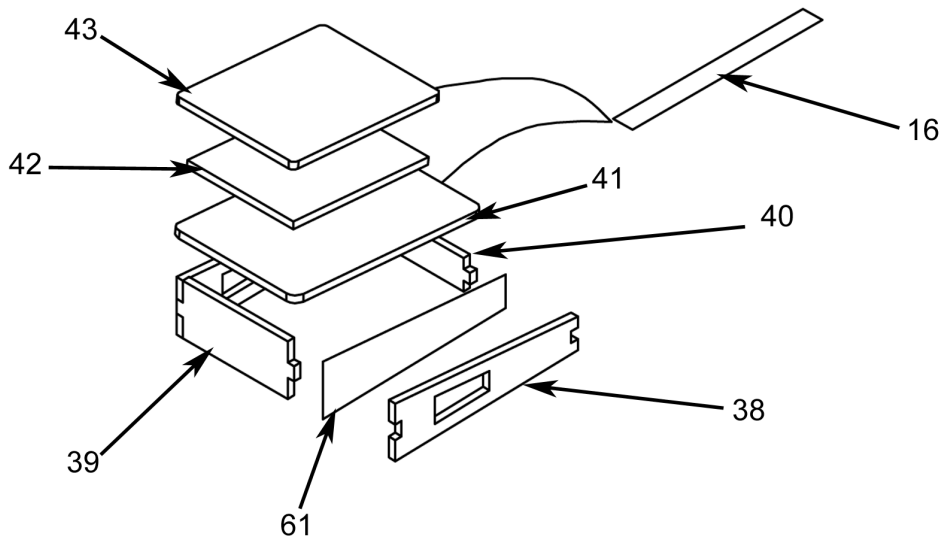
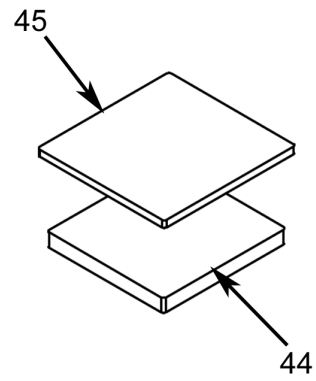
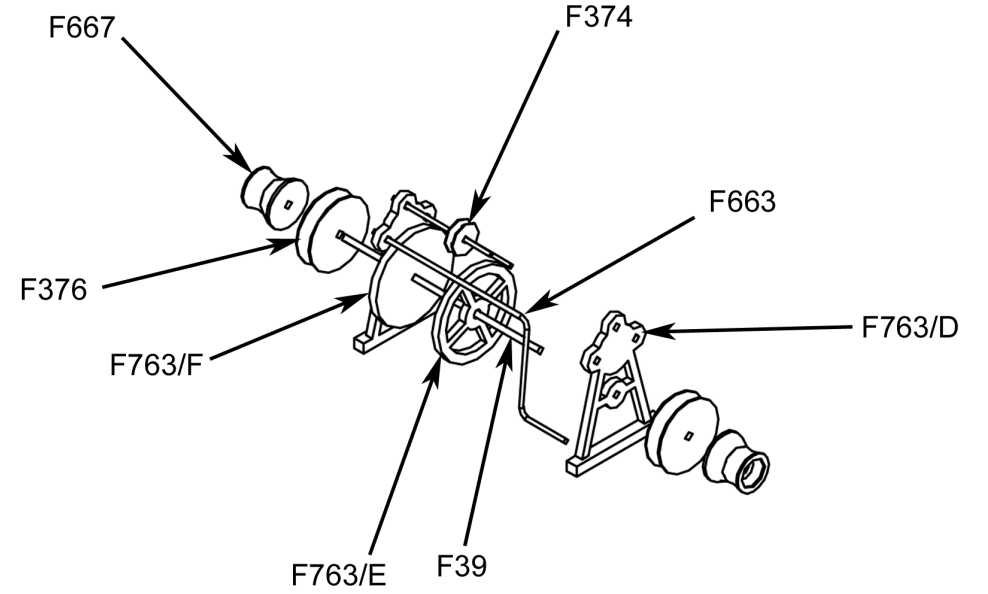
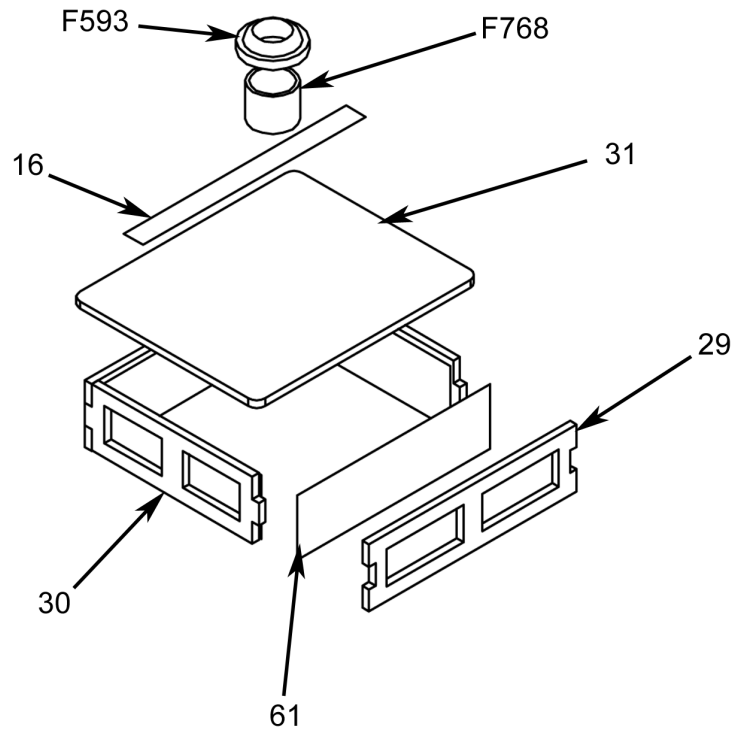













FIG.10









Symboler  = Rigningsnummer
 = Farvenummer
 = Bejdse



Symbols  = Rigging No.
 = Colour No.
 = Stain



Zeichen  = Takel Nr.
 = Farben Nr.
 = Beize

Symboles  = Greement no.
 = Couleur no.
 = Mordant

Symbolen  = Tuigage Nr.
 = Kleur Nr.
 = Beits

Símbolo  = Oparejo Nr.
 = Color Nr.
 = Mordiente

Segno  = Attrezzatura N°
 = Colore N°
 = Inchiostro tint.

Simbolos  = Cordame n°
 = Cõr n°
 = Tintura

Til denne model er mahogni bejdse og farver (Humbrol) med følgende numre nødvendige:

For this model is mahogany stain and colours (Humbrol) with the following numbers should be used:

Für dieses Modell sind Mahagoni Beize und Farben (Humbrol) mit den folgenden Nummern notwendig:

Pour ce modèle, le mordant et les couleurs (Humbrol) avec les numéros suivants doivent être employées:

Voor dit model zijn kleuren (Humbrol) met de volgende nummers nodig:

Para est modelo se necesitan mordiente et colores (Humbrol) con los siguientes números:

Per questo modello occorrono inchiostro tinteggiatore "mogano" e colori (Humbrol) con questi numeri:

Pinte o modelo com tintura cõr Mogno e as cõres sugeridas da Billing Boats (ou Humbrol):



Table contents for "Colin Archer" Art. No. 606

Pcs	No.	Dimension	Material	DK	GB	D	F
1	0	2mm x-finer	3093L	Køl	Keel	Kiel	Quille
1	0	2mm x-finer	3094L	Køl	Keel	Kiel	Quille
2	1	3mm x-finer	3095L	Spant	Frame	Spant	Couples
2	2	3mm x-finer	3095L	Spant	Frame	Spant	Couples
2	3	3mm x-finer	3095L	Spant	Frame	Spant	Couples
2	4	3mm x-finer	3095L	Spant	Frame	Spant	Couples
2	5	3mm x-finer	3095L	Spant	Frame	Spant	Couples
2	6	3mm x-finer	3095L	Spant	Frame	Spant	Couples
2	7	3mm x-finer	3095L	Spant	Frame	Spant	Couples
2	8	3mm x-finer	3095L	Spant	Frame	Spant	Couples
2	9	3mm x-finer	3095L	Spant	Frame	Spant	Couples
2	10	3mm x-finer	3095L	Spant	Frame	Spant	Couples
1	11	1mm x-finer	3091L	Dæk	Deck	Deck	Pont
1	11	1mm x-finer	3092L	Dæk	Deck	Deck	Pont
40	12	1,8x5x450mm	Obechi	Liste	Strip	Leiste	Baquette
2	13	2mm x-finer	3093L	Skandæk	Covering board	Schandeck	Plat-bord
2	14	1,8x7x550mm	Obechi	Liste	Strip	Leiste	Baquette
1	15	2mm x-finer	3093L	Ror	Rudder	Ruder	Gouvernail
1	15	2mm x-finer	3094L	Ror	Rudder	Ruder	Gouvernail
30	16	0,7x3x450mm	Koto	Liste	Strip	Leiste	Baquette
1	17	2,8x4x550	Obechi	Liste	Strip	Leiste	Baquette
2	18	1mm x-finer	3091L	Ræling	Rail	Reling	Plat-bord
2	19	1mm x-finer	3092L	Skanseklædning	Formed pieces	Schanzkleid	Pièces préfabrique
1	20	2mm x-finer	3094L	Cockpit	Cockpit	Plicht	Cockpit
2	21	2mm x-finer	3094L	Cockpit	Cockpit	Plicht	Cockpit
1	22	2mm x-finer	3094L	Cockpit	Cockpit	Plicht	Cockpit
1	23	2mm x-finer	3094L	Cockpit	Cockpit	Plicht	Cockpit
1	24	2mm x-finer	3094L	Cockpit	Cockpit	Plicht	Cockpit
1	25	2mm x-finer	3094L	Cockpit	Cockpit	Plicht	Cockpit
1	26	2mm x-finer	3093L	Mastering	Mast hoop	Mastring	Cercle de mât
2	27	2mm x-finer	3093L	Kranbjælke	Cran	Kranbalken	Grue
1	28	2mm x-finer	3093L	Rorbuk	Rudderlock	Ruderbock	Chevalet de gouvernail
2	29	1mm x-finer	3091L	Skylight	Skylight	Oberlicht	Claire voie
2	30	1mm x-finer	3091L	Skylight	Skylight	Oberlicht	Claire voie
1	31	1mm x-finer	3091L	Luge	Hatch	Luke	Ecoutilles
2	32	1mm x-finer	3091L	Skylight	Skylight	Oberlicht	Claire voie
1	33	1mm x-finer	3091L	Skylight	Skylight	Oberlicht	Claire voie
1	34	1mm x-finer	3091L	Skylight	Skylight	Oberlicht	Claire voie
1	35	1mm x-finer	3091L	Luge	Hatch	Luke	Ecoutilles

1	36	1mm x-finer	3091L	Luge	Hatch	Luke	Ecoutilles
1	37	1mm x-finer	3091L	Luge	Hatch	Luke	Ecoutilles
2	38	1mm x-finer	3091L	Skylight	Skylight	Oberlicht	Claire voie
1	39	1mm x-finer	3091L	Skylight	Skylight	Oberlicht	Claire voie
1	40	1mm x-finer	3091L	Skylight	Skylight	Oberlicht	Claire voie
1	41	1mm x-finer	3091L	Luge	Hatch	Luke	Ecoutilles
1	42	1mm x-finer	3091L	Luge	Hatch	Luke	Ecoutilles
1	43	1mm x-finer	3091L	Luge	Hatch	Luke	Ecoutilles
1	44	2mm x-finer	3094L	Luge	Hatch	Luke	Ecoutilles
1	45	1mm x-finer	3091L	Luge	Hatch	Luke	Ecoutilles
1	46	5x5x125mm	Obechi	Luge	Hatch	Luke	Ecoutilles
1	47	Ø4x75mm	Ramin	Rundstok	Round stick	Rundstab	Baquette ronde
1	48	2mm x-finer	3093L	Naglebænk	Pin rail	Nagelbank	Râtelier
1	49	M10	Ramin	Mast	Mast hoop	Mast	Mât
1	50	2mm x-finer	3093L	Kindbakker	Gripes	Kinnbacken	Jottereaux
1	51	R2	Ramin	Bom	Bar	Baum	Bome
1	52	M0	Ramin	Bom	Bar	Baum	Bome
1	53	R5	Ramin	Stortoprå	Masthead yard	Grossgaffel	Grande corne
1	54	M11	Ramin	Bovspryd	Bowsprit	Bugsprit	Blaupré
1	55	M2	Ramin	Mast	Mast	Mast	Mât
1	56	2mm x-finer	3093L	Kindbakker	Gripes	Kinnbacken	Jottereaux
2	57	R0	Ramin	Bom	Bar	Baum	Bome
1	58	4mm x-finer	3096L	Bedding	Slip	Ständer	Cale
1	59	4mm x-finer	3096L	Bedding	Slip	Ständer	Cale
2	60	Ø5x100mm	Ramin	Bedding	Slip	Ständer	Cale
1	61	50x50mm	Acetat	Vindue	Window	Fenster	Fenetres
1	62	360x105x6mm	MDF	Byggebræt	Slip	Helling	Cale
1	63		TR 167	Transfer	Transfer	Transfer	Decals
1	64		FL 144	Flag	Flag	Flaggen	Drapeau

Table contents for fittingkit "Colin Archer" Art. No. 606

Pcs	No.	Dimension	DK	GB	D	F
2	F24	Ø20mm	Redningsbælter	Lifebelts	Rettungsringe	Ceinture de Sauvetage
1	F34	23mm	Lanternekasse	Board for sidelight	Laternenkasten	Plachette pour les de position
1	F39	Ø1x250mm	Messingtråd	Brass wire	MS-Draht	Fil de laiton
1	F41	12mm	Klampe	Cleats	Klampen	Taquets
16	F54	8mm	Kofilnagle	Belaying pins	Belägnägel	Cabillots
1	F57	35mm	Anker	Anchor	Anker	Ancre
1	F62	Ø4mm	Klokke	Bell	Glocke	Cloche
1	F70	30m	Rigningstråd	Riggingthread	Takelgarn	Fil de greement
1	F72	3m	Rigningstråd	Riggingthread	Takelgarn	Fil de greement
3	F100	Ø4mm	Lanterne	Light	Laternen	Lanterne
2	F121	Ø6mm	Lanterne	Light	Laternen	Lanterne
18	F230	10mm	Søm	Pins	Nägel	Clous
2	F317	Ø4mm	Klyds	Fairlead	Verhölklüse	Chaumard
1	F327	250mm	Kæde	Chain	Kette	Chaîne
2	F347	Ø6mm	Mastetop	Masthead	Masttop	Tête de mât
2	F348	9mm	Klampe	Cleats	Klampen	Taquets
1	F374	Ø4mm	Rulle	Roll	Rollen	Pouliers
2	F376	Ø8mm	Rulle	Roll	Rollen	Pouliers
1	F404	10mm	Søm	Pins	Nägel	Clous
1	F409	Ø1,5x100mm	Messingtråd	Brass wire	MS-Draht	Fil de laiton
1	F501	Ø4mm	Mastering	Mast hoop	Mastring	Cercle de mât
1	F504	Ø7mm	Ring	Hoop	Ring	Cercle de mât
1	F526	Ø9mm	Mastebeslag	Mast fitting	Mastbeschlag	Garniture de mât
1	F528	Ø7mm	Mastebeslag	Mast fitting	Mastbeschlag	Garniture de mât
9	F539	40mm	Røstjern	Chainplate	Rüsteisen	Cadènes
1	F593	Ø8mm	Ventil	Vent	Lüfter	Manche air luchtkoker
2	F663	Ø0,7x250mm	Messingtråd	Brass wire	MS-Draht	Fil de laiton
22	F664	11mm	Øjebolt	Eye bolt	Augenbolzen	Pitons
2	F667	Ø6mm	Spilkop	Warping end	Spillkopf	Tambour
30	F697	5mm	Blok, enkelt	Block, single	Block, einzel	Poulie, simple
2	F743	9mm	Øjebolt	Eye bolt	Augenbolzen	Pitons
1	F763		Plaststøb	Plaststeep	Plastic spritzling	Plastique moulage
1	F767	4mm	Blok, enkelt	Block, single	Block, einzel	Poulie, simple
1	F768	Ø6x5mm	Ventil	Vent	Lüfter	Manche air luchtkoker
12	F769	25mm	Gelanderstøtte	Railstanchion	Geländerstützen	Chandeliers
16	F821	Ø3,5mm	Jomfru	Dead eye	Junfern	Cap de Mouton

Table contents for "Colin Archer" Art. No. 606

Pcs	No.	Dimensions	Material	NL	E	I	P
1	0	2mm x-finer	3093L	Kiel	Quilla	Chiglia	Quilha
1	0	2mm x-finer	3094L	Kiel	Quilla	Chiglia	Quilha
2	1	3mm x-finer	3095L	Spant	Cuaderna	Ordinata	Armacao
2	2	3mm x-finer	3095L	Spant	Cuaderna	Ordinata	Armacao
2	3	3mm x-finer	3095L	Spant	Cuaderna	Ordinata	Armacao
2	4	3mm x-finer	3095L	Spant	Cuaderna	Ordinata	Armacao
2	5	3mm x-finer	3095L	Spant	Cuaderna	Ordinata	Armacao
2	6	3mm x-finer	3095L	Spant	Cuaderna	Ordinata	Armacao
2	7	3mm x-finer	3095L	Spant	Cuaderna	Ordinata	Armacao
2	8	3mm x-finer	3095L	Spant	Cuaderna	Ordinata	Armacao
2	9	3mm x-finer	3095L	Spant	Cuaderna	Ordinata	Armacao
2	10	3mm x-finer	3095L	Spant	Cuaderna	Ordinata	Armacao
1	11	1mm x-finer	3091L	Dek	Cubierta	Coperta	Deck
1	11	1mm x-finer	3092L	Dek	Cubierta	Coperta	Deck
40	12	1,8x5x450mm	Obechi	Strip	Listón	Listello	Tira
2	13	2mm x-finer	3093L	Dekstrip	Listón de cubierta	Soglia	Base da amurada
2	14	1,8x7x550mm	Obechi	Strip	Listón	Listello	Tira
1	15	2mm x-finer	3093L	Roer	Timón	Timone	Leme
1	15	2mm x-finer	3094L	Roer	Timón	Timone	Leme
30	16	0,7x3x450mm	Koto	Strip	Listón	Listello	Tira
1	17	2,8x4x550	Obechi	Strip	Listón	Listello	Tira
2	18	1mm x-finer	3091L	Reling	Borda	Parapetto	Amurada superior da
2	19	1mm x-finer	3092L	Gevormd deel	Bularte	Parapetto di murata	Baluarte
1	20	2mm x-finer	3094L	Kuip	Bañera	Pozzetto	Cabine do piloto
2	21	2mm x-finer	3094L	Kuip	Bañera	Pozzetto	Cabine do piloto
1	22	2mm x-finer	3094L	Kuip	Bañera	Pozzetto	Cabine do piloto
1	23	2mm x-finer	3094L	Kuip	Bañera	Pozzetto	Cabine do piloto
1	24	2mm x-finer	3094L	Kuip	Bañera	Pozzetto	Cabine do piloto
1	25	2mm x-finer	3094L	Kuip	Bañera	Pozzetto	Cabine do piloto
1	26	2mm x-finer	3093L	Mastdoorvoer	Zunzho	Anello dell'albero	Anel do mastro
2	27	2mm x-finer	3093L	Kraanbalk	Grúa	Trave del gru	Guindaste
1	28	2mm x-finer	3093L	Steun	Soporte del timón	Soporte del timón	Suporte do manipulo
2	29	1mm x-finer	3091L	Bovenlicht	Lumbrera	Osteriggio	Clarabóia
2	30	1mm x-finer	3091L	Bovenlicht	Lumbrera	Osteriggio	Clarabóia
1	31	1mm x-finer	3091L	Luikdeel	Escotilla	Boccaporto	Escotilha
2	32	1mm x-finer	3091L	Bovenlicht	Lumbrera	Osteriggio	Clarabóia
1	33	1mm x-finer	3091L	Bovenlicht	Lumbrera	Osteriggio	Clarabóia
1	34	1mm x-finer	3091L	Bovenlicht	Lumbrera	Osteriggio	Clarabóia
1	35	1mm x-finer	3091L	Luikdeel	Escotilla	Boccaporto	Escotilha

1	36	1mm x-finer	3091L	Luikdeel	Escotilla	Boccaporto	Escotilha
1	37	1mm x-finer	3091L	Luikdeel	Escotilla	Boccaporto	Escotilha
2	38	1mm x-finer	3091L	Bovenlicht	Lumbrera	Osteriggio	Clarabóia
1	39	1mm x-finer	3091L	Bovenlicht	Lumbrera	Osteriggio	Clarabóia
1	40	1mm x-finer	3091L	Bovenlicht	Lumbrera	Osteriggio	Clarabóia
1	41	1mm x-finer	3091L	Luikdeel	Escotilla	Boccaporto	Escotilha
1	42	1mm x-finer	3091L	Luikdeel	Escotilla	Boccaporto	Escotilha
1	43	1mm x-finer	3091L	Luikdeel	Escotilla	Boccaporto	Escotilha
1	44	2mm x-finer	3094L	Luikdeel	Escotilla	Boccaporto	Escotilha
1	45	1mm x-finer	3091L	Luikdeel	Escotilla	Boccaporto	Escotilha
1	46	5x5x125mm	Obechi	Luikdeel	Escotilla	Boccaporto	Escotilha
1	47	Ø4x75mm	Ramin	Rondhout	Barra reronda	Tondino	Bastão cilíndrico
1	48	2mm x-finer	3093L	Nagelbank	Cabilleros	Cavigliera	Pino da amurada
1	49	M10	Ramin	Mast	Palo	Albero	Mastro
1	50	2mm x-finer	3093L	Ezelshoofd	Mandibula	Ganasce	Juncão
1	51	R2	Ramin	Boom	Botavara	Asta	Botaló
1	52	M0	Ramin	Boom	Botavara	Asta	Botaló
1	53	R5	Ramin	Spriet	Verga del palo grande	Picco di maestra	Verga da cabeça do
1	54	M11	Ramin	Boegspriet	Baupres	Albero di bompresso	Mastro de Proa
1	55	M2	Ramin	Mast	Palo	Albero	Mastro
1	56	2mm x-finer	3093L	Ezelshoofd	Mandibula	Ganasce	Juncão
2	57	R0	Ramin	Boom	Botavara	Asta	Botaló
1	58	4mm x-finer	3096L	Standaard	Grada	Supporto	Pé do Suporte de Casco
1	59	4mm x-finer	3096L	Standaard	Grada	Supporto	Pé do Suporte de Casco
2	60	Ø5x100mm	Ramin	Standaard	Grada	Supporto	Pé do Suporte de Casco
1	61	50x50mm	Acetat	Raam	Ventana	Finestrini	Janelal
1	62	360x105x6mm	MDF	Standaard	Grada	Asse da montaggio (scalo)	Carreira
1	63		TR 167	Transfer	Transfer	Decalcomanie	Decalques
1	64		FL 144	Vlag	Bandera	Bandiere	Bandeira

Table contents for fittingkit "Colin Archer" Art. No. 606

Pcs	No.	Dimension	NL	E	I	P
2	F24	Ø20mm	Reddingsgordel	Cinturones salvavid	Salvagente	Bóia salva-vides
1	F34	23mm	Lichtbakken	Cajas para linternas	Cassa lanterna	Suporte da luz lateral
1	F39	Ø1x250mm	Messingdraad	Hilo de latón	Filo di ottone	Fio de latão
1	F41	12mm	Kikker	Cornamusas	Gallocce	"T" de amarra (castanhas)
16	F54	8mm	Korvijnnagel	Cabillas	Ribattini	Pino de amarracão
1	F57	35mm	Anker	Ancla	Ancora	Âncora
1	F62	Ø4mm	Scheepbel	Campanilla	Campana	Sino
1	F70	30m	Takelgaren	Hilo de oparejo	Filo per manovre	Linha de cordame
1	F72	3m	Takelgaren	Hilo de oparejo	Filo per manovre	Linha de cordame
3	F100	Ø4mm	Boordlichten	Linternas	Lanterna di bordo	Luzes
2	F121	Ø6mm	Boordlichten	Linternas	Lanterna di bordo	Luzes
18	F230	10mm	Spijkertje	Clavo	Chiodini	Pinos
2	F317	Ø4mm	Verhallklamp	Bocina	Passacavo	Escovém
1	F327	250mm	Ketting	Cadena	Catena	Corrente
2	F347	Ø6mm	Masttop	Extremo superio de palo	Estremitá superiore del palo	Topo de mastro
2	F348	9mm	Kikker	Cornamusas	Gallocce	"T" de amarra (castanhas)
1	F374	Ø4mm	Schjif	Rodillos	Pulegge	Polias
2	F376	Ø8mm	Schjif	Rodillos	Pulegge	Polias
1	F404	10mm	Spijkertje	Clavo	Chiodini	Pinos
1	F409	Ø1,5x100mm	Messingdraad	Hilo de latón	Filo di ottone	Fio de latão
1	F501	Ø4mm	Hoepel	Zunzho	Anello dell'albero	Topo de mastro
1	F504	Ø7mm	Ring	Cercla	Anello	Anel
1	F526	Ø9mm	Mastbeslag	Herrajes de palo	Accessori albero	Anel do mastro de pôpa
1	F528	Ø7mm	Mastbeslag	Herrajes de palo	Accessori albero	Anel do mastro de pôpa
9	F539	40mm	Puttings	Cadenote	Landra	Fixador do ovém
1	F593	Ø8mm	Luchtkoker	Vávula	Valvola	Respiradouro
2	F663	Ø0,7x250mm	Messingdraad	Hilo de latón	Filo di ottone	Fio de latão
22	F664	11mm	Oogbauten	Pernos de cânamo	Bullone ad occhio	Ferrolho
2	F667	Ø6mm	Winchkop	Tambor	Testa argano	Tambor di guindaste
30	F697	5mm	Enkel blok	Polea, simple	Blocco, singolo	Bloco, simples
2	F743	9mm	Oogbauten	Pernos de cânamo	Bullone ad occhio	Ferrolho
1	F763		Plastic gietraam	Piezas de plástico fundido	Pezzo stampato ad	Pecas injetadas
1	F767	4mm	Enkel blok	Polea, simple	Blocco, singolo	Bloco, simples
1	F768	Ø6x5mm	Luchtkoker	Vávula	Valvola	Respiradouro
12	F769	25mm	Relingpaal	Soporte de pasamanos	Supporti per il corrimano	Pontalete da amurada
16	F821	Ø3,5mm	Jufferblokken	Virgenes	Testa di montone	Bigota

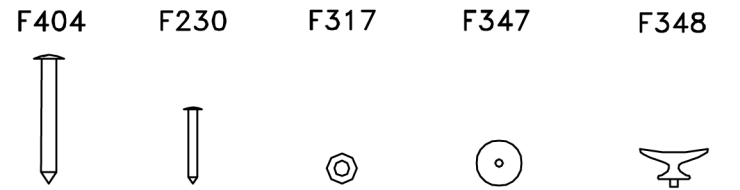
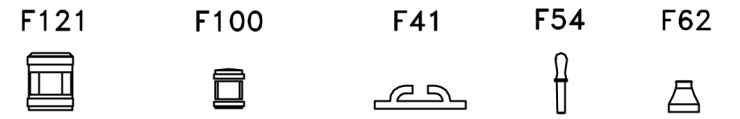
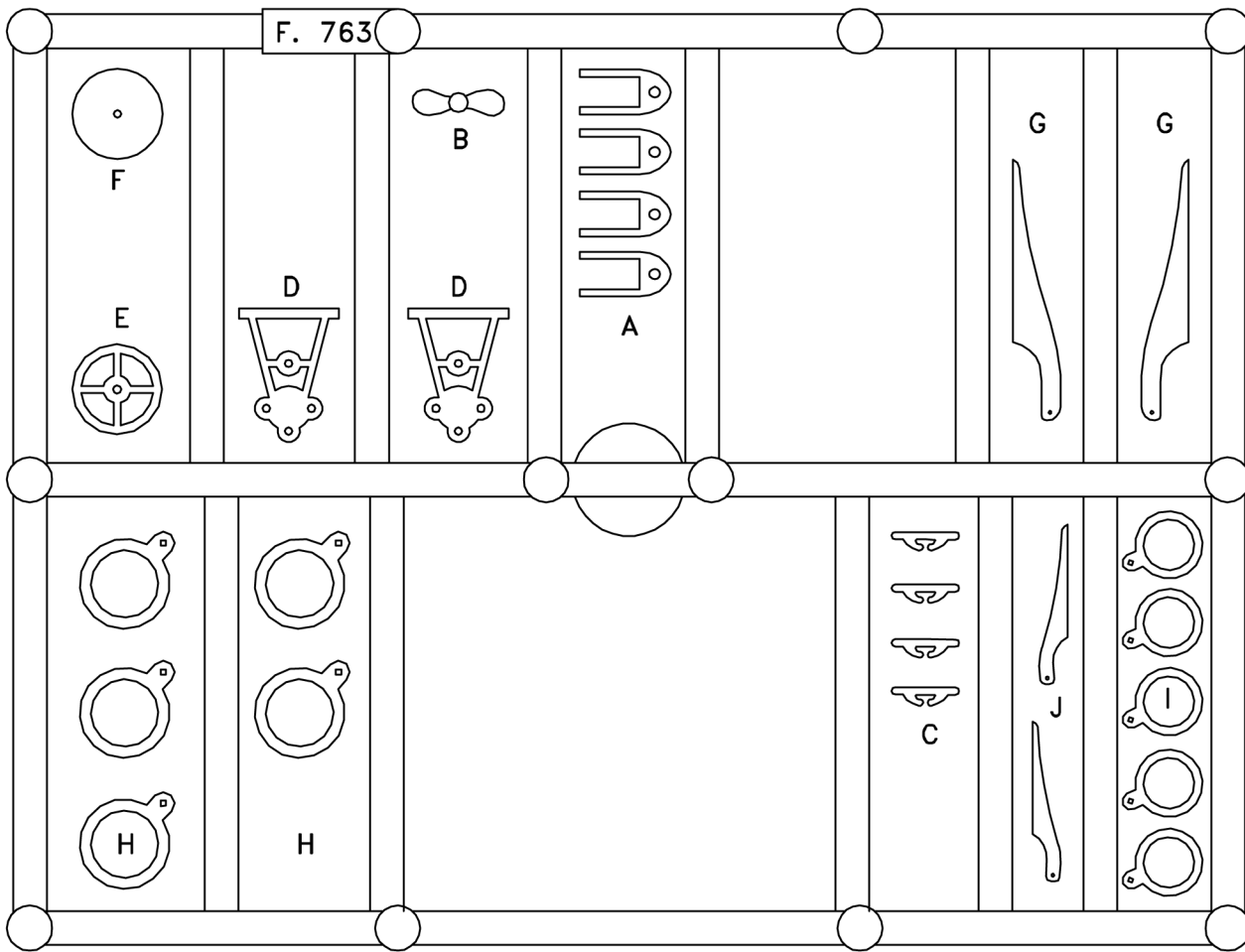

F24

F34

F769

F539

F57

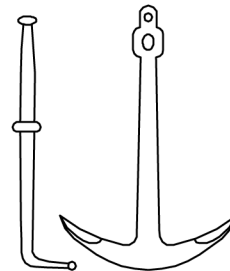
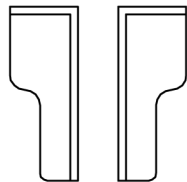
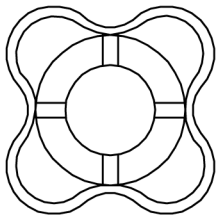

F667

F697

F767

F821

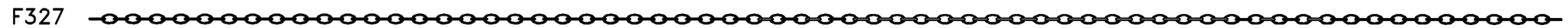
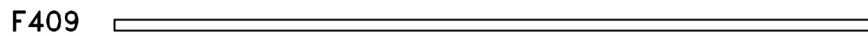

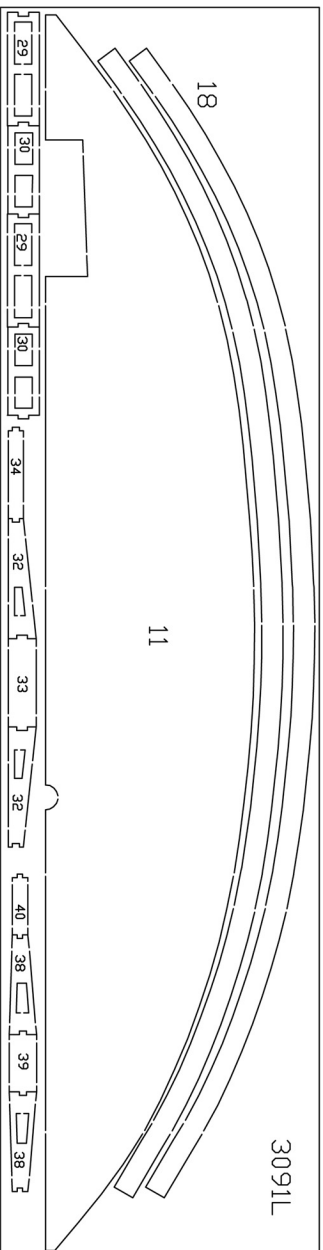
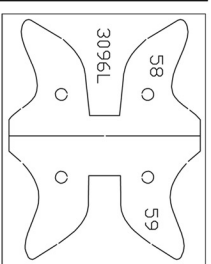

3091L



606-1LO

Colin Archer

No.606

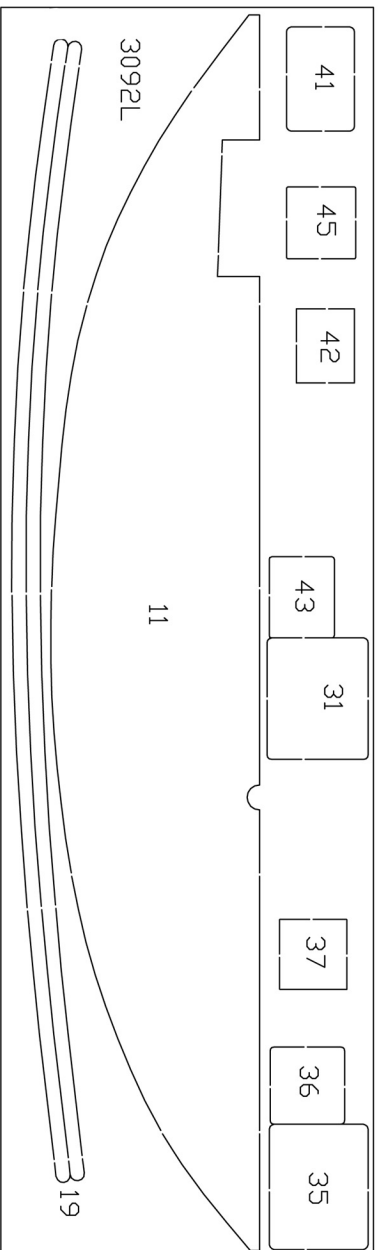

3092L

11

19

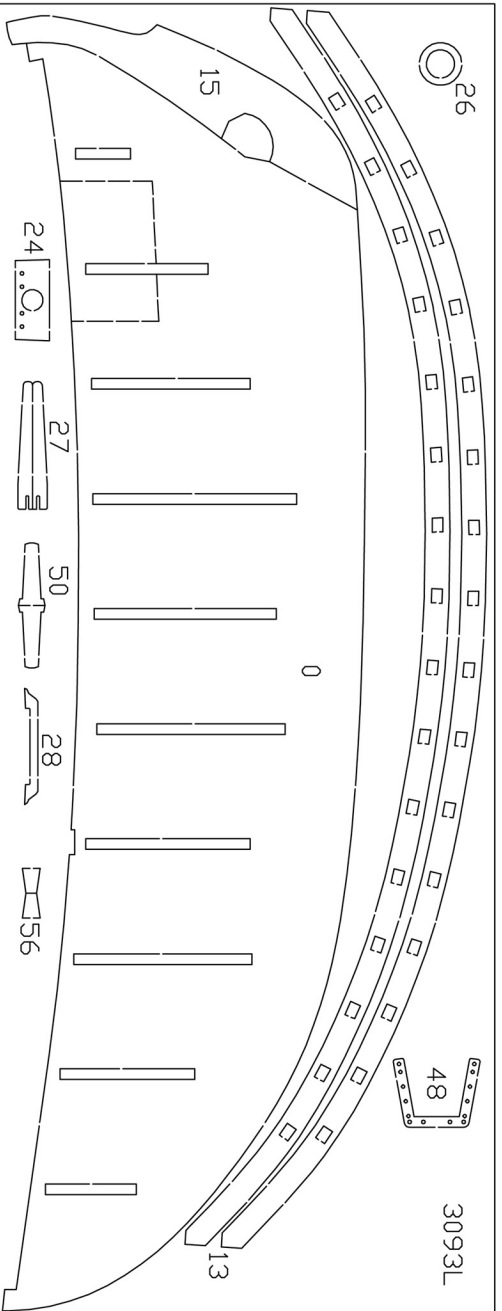

26

15

24

27

50

28

56

48

13

0

3093L

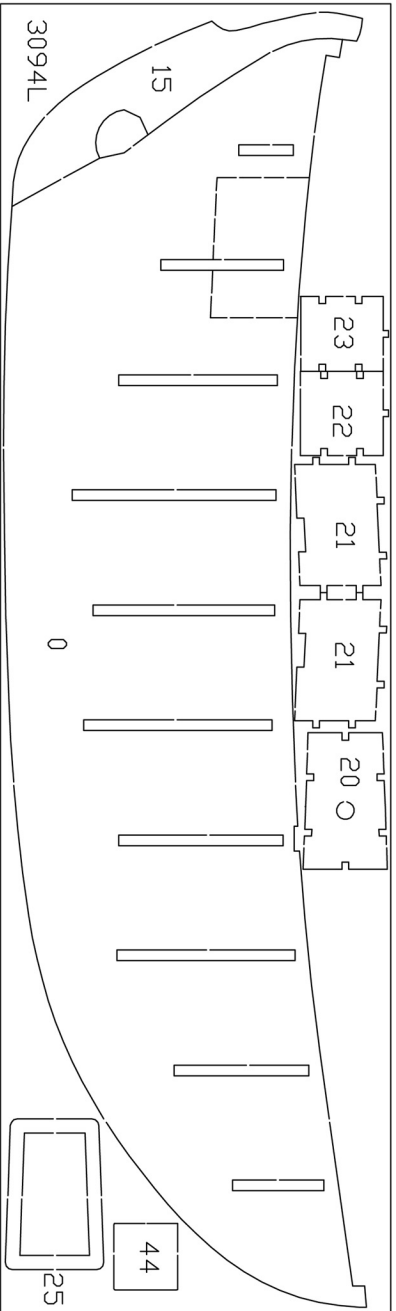

3094L

15

23

22

21

21

20

0

44

25

3094L

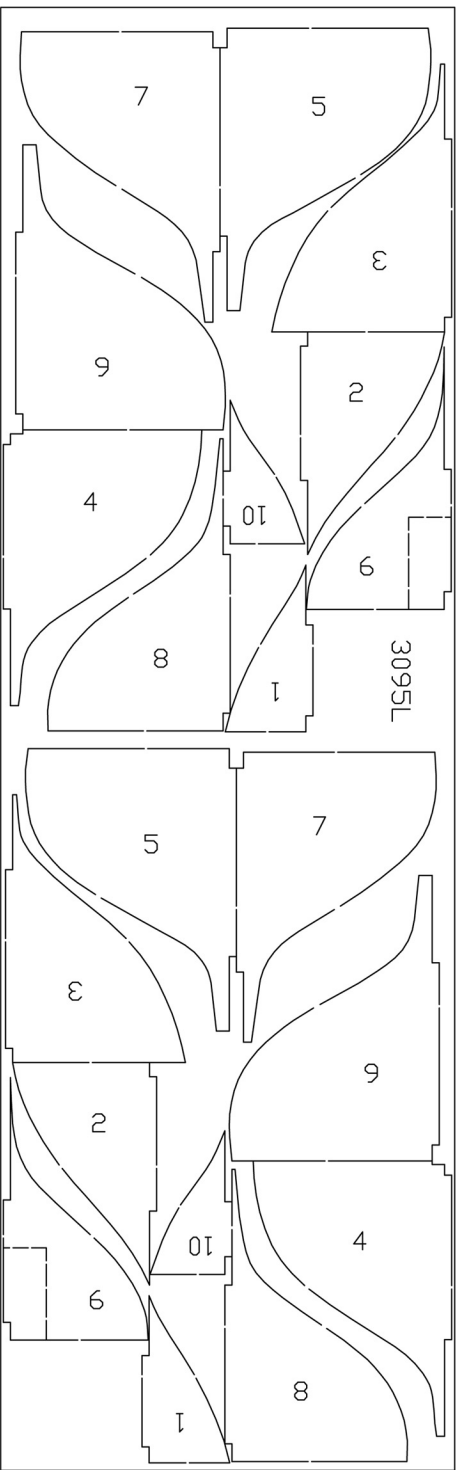

3095L

5

3

2

9

10

1

7

6

4

8

5

7

3

2

4

10

9

8

1

